

Wireless World

ELECTRONICS, RADIO, TELEVISION

Managing Editor: HUGH S. POCOCK, M.I.E.E.

Editor: H. F. SMITH

Assistant Editor: F. L. DEVEREUX, B.Sc.

NOVEMBER 1956

In This Issue

Editorial Comment	519
Personal Paging System	520
World of Wireless	522
Disc Recording Characteristics	<i>J. D. Smith</i> 526
Transistor D.C. Amplifier	<i>D. M. Neale and Francis Oakes</i> 529
Automatic Wavemeter Calibration	<i>D. P. Thurnell</i> 533
Letters to the Editor	536
Short-Wave Conditions	537
Pocket Transistor Receiver	<i>P. Tharma</i> 538
Stereophony in the Home	<i>J. Moir</i> 541
Transistor R.F. Amplifiers—2	<i>D. D. Jones</i> 544
Books Received	546
International Acoustics Conference	547
Amateur Television	<i>M. Barlow</i> 548
Radio Pictures on Tape	550
Colonial Broadcasting	<i>J. W. Murray</i> 551
Modifying Upper-Sideband Television Receivers	<i>G. J. Conway</i> 552
The Great Transistor Chaos	"Cathode Ray" 554
Four-Standards Television	<i>H. de Laistre Banting</i> 559
Inexpensive Variable-Slope Filter	<i>D. M. Leakey</i> 563
November Meetings	565
Random Radiations	"Diallist" 566
Unbiased	"Free Grid" 568

VOLUME 62 No. 11
PRICE: TWO SHILLINGS

FORTY-SIXTH YEAR
OF PUBLICATION

PUBLISHED MONTHLY (4th Tuesday of preceding month) by ILIFFE & SONS LTD., Dorset House, Stamford Street, London S.E.1
Telephone: Waterloo 3333 (60 lines). Telegrams: "Ethaworld Scdist London." Annual Subscription: Home and Overseas £1 12s. 6d.
U.S.A. and Canada \$5.00 BRANCH OFFICES: BIRMINGHAM: King Edward House New Street, 2. Telephone: Midland 7191.
COVENTRY: 8-10 Corporal Street. Telephone: Coventry 5210. GLASGOW: 28B Renfield Street, C.2. Telephone: Central 1275.
MANCHESTER: 260, Deansgate 3. Telephone: Blackfriars 4412. OVERSEAS OFFICES: U.S.A.: 111 Broadway New York 6, N.Y. Telephone: Digby 9-1197 CANADA: 74 College Street, Toronto, 2 Ontario Telephone: Walnut 4-5631

Transistor



High Gain Preamplifier

A high gain transistor preamplifier is described which uses a single OC70 in grounded emitter connection. The supply voltage is 250V and the load more than 330k Ω . The basic circuit arrangement is shown at 'A'.

The preamplifier has distinct advantages over a thermionic valve preamplifier. First, two valves would be required to get comparable gain. Second, thermal noise is sufficiently low for it to approach that of a valve circuit, and the transistor preamplifier is of course completely free from hum and microphony. The current drain is low, about 0.7mA from the 250V supply.

This preamplifier has comparatively high output impedance and best results are obtained when it is fed into the high input impedance of a thermionic valve amplifier. It can be used with low impedance microphones, pickups and tape heads. For a nominal circuit, with an input voltage of 5.5mV and a gain of about 330, the output voltage is about 1.8V. The input impedance at X-X is 200 Ω and the output impedance at Y-Y is of the order of 5k Ω . The frequency response depends to a certain extent on the source impedance. With a 50 Ω source a 3dB reduction in gain is reached at 15c/s and 12kc/s.

Although designed for a 250V supply voltage the preamplifier operates usefully with supply voltages down to as little as 100V. It can be used successfully with a 30 Ω /50 Ω microphone and a 100V supply coming from a valve amplifier into which it feeds.

The preamplifier can be fed from the same supply as a valve amplifier by rearranging the circuit as at 'B'. In the setup shown at 'B' one side of the output is earthed, whereas in 'A' the input and output are 'floating' at some voltage above the chassis. The input is fed between base and emitter through R1 and C1 so that R5 does not contribute a.c. negative feedback but forms part of the load. The output in 'A' can be taken from between C2 and chassis if desired, but it then becomes slightly smaller than when taken from C2-C3, because R5 no longer forms part of the load. Although the input terminals in both 'A' and 'B' are 'floating', there should be no risk of hum being introduced provided the preamplifier is mounted reasonably close to the microphone or pickup.

If the circuit is used in arrangement 'A' care must be taken not to short the input terminals to earth. In the arrangement shown at 'B' the current through the pickup or microphone will not be excessive if the input is accidentally shorted to earth.

High voltage gain is obtained from a transistor in the same way as for a pentode valve, by operating it with a high load and feeding from a high supply voltage. In both 'A' and 'B' sufficient d.c. stabilisation is provided by the potential divider R2-R3 and emitter resistor R5 to ensure satisfactory operation up to an ambient temperature of 45°C (110°F). Besides the d.c. feedback provided by R2, R3 and R5, there is an a.c. feedback path formed by R2, R1 and the source impedance, all

in series. Part of the a.c. voltage developed across this potential divider is tapped off and fed back into the base. By including a 100 Ω resistor R1 in the a.c. feedback path, effective feedback is ensured even when the source impedance is very small. Apart from improving the frequency response and reducing distortion, the a.c. negative feedback decreases the input and output impedances. If thought desirable a.c. feedback can be prevented by making R2 up of two nearly equal resistances and bypassing the common point to ground by a suitable capacitance, of the order of 0.5 μ F.

Even with a supply voltage of 250V the circuit is so designed that the collector to emitter voltage never exceeds the d.c. voltage rating of $V_{c,max} = -5V$ for the OC70 under the worst possible combination of conditions. The effect of resistance tolerances, supply tolerances, change of ambient temperature, and spread in transistor characteristics have all been considered in the design. In order to keep available the maximum voltage across the transistor, while allowing a tolerance of $\pm 10\%$ on the supply voltage, the resistor tolerances must be within $\pm 5\%$ to prevent the 5V rating from being exceeded. High stability resistors should be used. For a nominal circuit the collector current is 0.7mA and the collector to emitter voltage approximately 4V. An OC70 with a low current amplification factor a' and low leakage current $I'_{c(e)}$ in grounded emitter causes the highest collector to emitter voltage of 5V. A transistor at the other extreme gives a collector to emitter voltage of about 0.8V at the maximum ambient temperature of 45°C, and allows an output of about 400mV (r.m.s.).

If resistors of $\pm 10\%$ tolerance are used, the collector to emitter voltage should be metered to ensure that it does not exceed 5V. The performance is the same as for resistor tolerances of $\pm 5\%$ except that possibly less collector voltage swing will be available if all the resistors have their lowest extreme value.

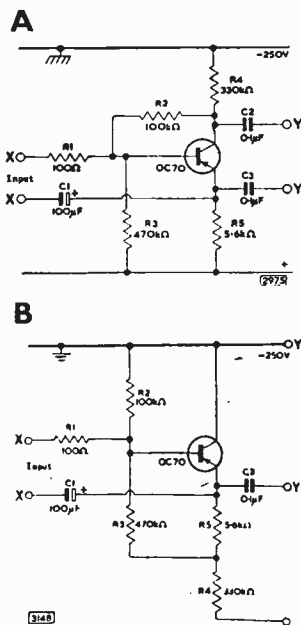

The circuit is similar to that described by James J. Davidson in an article called 'High Gain Transistor Amplifier,' published in Audio, October 1955.



625 Lines Again

IN the August issue of *Wireless World* we printed an article comparing, in the simplest possible terms, the picture quality offered by the various television systems that have been adopted in different parts of the world. The 625-line came out rather badly from that comparison, the conclusion being that better value could be obtained for the bandwidth employed. Before that article was published there was a body of opinion strongly in favour of adopting the continental standards for the projected British colour service. Since then, enthusiasm for 625 lines has waned notably.

However, there are still those who consider the benefits of standardization outweigh other considerations. Among these is Sir Robert Renwick, who again writes in our correspondence columns this month to urge the advantages of 625 lines in the interests of the export trade.

Is it possible to reach a compromise that will satisfy the requirements of standardization and at the same time overcome the technical shortcomings of the normal continental system? Such a compromise might quite easily be reached by modifying the standard 625-line system by widening the video bandwidth by about 1 Mc/s. That would provide for a picture of sensibly equal horizontal and vertical definition and the slight deviation from complete standardization should be no great embarrassment to the export trade. If we are in fact to have colour television incompatible with the present service, can we do better than tentatively adopt these modified 625-line standards?

We say "tentatively" because these discussions of definition standards for colour television seem to become more and more unrealistic as one considers the other and far more pressing problems that have to be tackled before practical receivers can be produced at an economic price. These problems were frankly discussed at the official opening of the Sylvania-Thorn colour television laboratories at Enfield on October 3rd. The spokesman of both the American and British companies co-operating in this new enterprise expressed open dissatisfaction with colour techniques as they exist today, and the opinion was expressed that an entirely new system was needed.

A new series of colour test transmissions by both the B.B.C and I.T.A. was announced recently, and it was stated that these would be on both 405 and

625 lines. This seems to offer an opportunity for trying the wide-band 625-line modification to which we have referred.

Power by Radio

THE centenary of the birth of Nikola Tesla is being celebrated this year in his native Yugoslavia and in the United States, his adopted country. Tesla made many important contributions to electrical engineering; in radio, he is mainly remembered for his attempts to transmit power by wireless. Looking back, it is safe to say he would have achieved greater success by concentrating his efforts on the substance of radio communication instead of on the shadow of power transmission. After more than half a century, that objective is still almost as far from attainment as in Tesla's day.

But the modest power requirements of the transistor have made us change our ideas as to what is worth while in the way of power transmission. Very opportunely coinciding with the Tesla centenary comes an article in an American journal* on the use of radio-transmitted power for the operation of transistorized receivers, navigational aids and other electronic equipment. Though important practical applications of the idea do not readily come to mind, it is of some academic interest.

For its simplest application "free power", as Dr. Hollmann calls it, is obtained by rectifying the carrier of a nearby broadcasting station with a crystal diode. The rectified and filtered output is then fed to transistors, which amplify and detect the signals of more distant stations.

A still more intriguing possibility is to make the wanted station supply the power for amplifying its own signals. At first sight that sounds impossible, but Dr. Hollmann claims that a receiver working in that way does in fact give a performance superior to that of a plain non-amplifying crystal set. The explanation he gives is that the plain crystal receiver derives its output power from the modulation envelope only; the carrier energy is wasted. In the amplifying receiver, on the other hand, the carrier is rectified to provide power for the amplifier, and so a greater output is obtainable.

* "Free Power Receivers" by H. E. Hollmann; *Electronic Industries*, Sept. 1956.

Personal Paging System

SELECTIVE INDUCTION METHOD

THE advantages offered by transistors in the design of small, lightweight equipment of low power consumption are particularly well emphasized by the new selective paging system recently installed at St. Thomas's Hospital, London. Here each member of the staff on call is equipped with a small transistor "receiver" which clips into a top pocket like a fountain pen (Fig. 1). It measures $5\frac{3}{4}$ in long by 1 in diameter and weighs only 5oz. The current consumption from the 1.35-V mercury cell is only 0.5mA in the quiescent condition (the receiver being permanently switched on) and 3mA when a call is being received, and this is reckoned to give a cell life of over two months.

Developed by Multitone in collaboration with St. Thomas's, the paging system works on the magnetic induction principle. A single loop of wire round the building carries audio frequency signals from a 70-watt amplifier and the magnetic field so generated is picked up in each "receiver" by a small coil with a laminated core (see Fig. 2). The system is made selective by assigning to each "receiver" a particular audio frequency which is transmitted as a call signal. There are 56 of these frequencies available altogether, in the range of 2-15 kc/s, and each "receiver" selects its own frequency by means of a high-Q tuned circuit. Reception of the call signal changes the bias of a local transistor a.f. oscillator, which emits an audible

1,000-c/s note through a miniature telephone ear-piece in the "cap" of the "fountain pen."

In the transmitting equipment (Fig. 3) each call frequency is selected by pressing a combination of buttons. This operation also causes the signal to be automatically coded, by a gating pulse generator, into a pattern of marks and spaces which means something to the recipient at the other end when he hears the resulting bursts of 1,000-c/s tone. The duration of the call signal is also determined automatically. Usually the code signal means "go to the nearest telephone to receive a message." The equipment is, however, capable of conveying speech signals in addition to the code signals. Here, a code signal is transmitted first which means "prepare to receive speech." The recipient then presses a button on the side of the "pen," which puts the high-Q selector circuit out of action (and also the 1,000-c/s oscillator), and he places the instrument near to his ear.

At the transmitter a "speech" key is operated which takes out of circuit the pulse generator producing the code sequences and switches in a crystal microphone and amplifier. The tendency for the speech signals (which, of course, cover a wide band) to trigger the selector tuned circuits of other "receivers" is avoided by transmitting the speech



Fig. 1. The "receiver" clipped into a top pocket.

Fig. 2. Interior views of the receiver with the tubular housing removed.

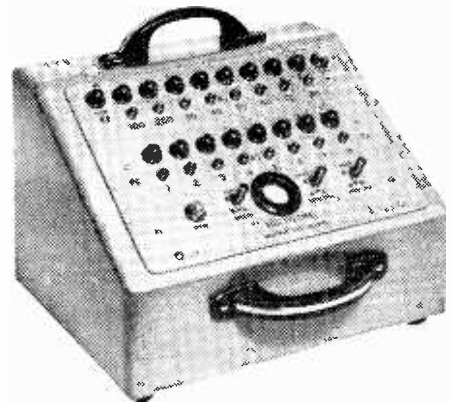
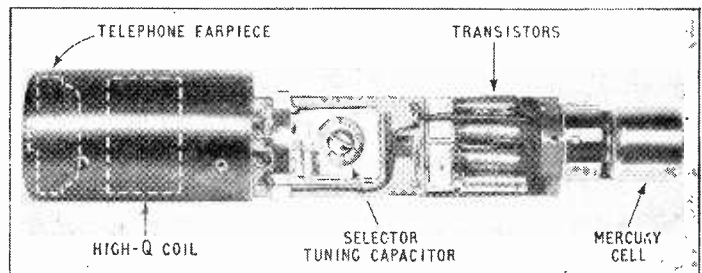
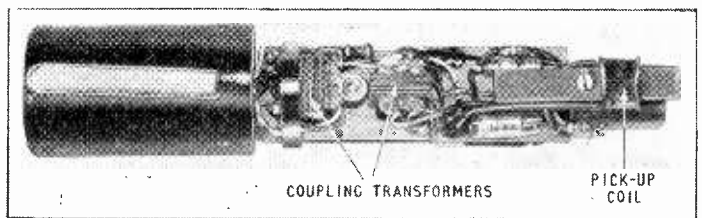

Fig. 3. The transmitting equipment and control panel.

on lower power. This occurs automatically because the loop is tuned for the individual code signal frequencies but not for speech.

The construction of the "fountain pen" receiver can be seen from Fig. 2. At the bottom end is the mercury cell, then the pick-up coil and the 3-stage transistor circuit which amplifies the

induced currents. Transformer coupling is used between stages and all components are miniature types except the trimmer capacitor for tuning the high-Q selector circuit. The coil for this tuned circuit is enclosed in a ferrite "pot" core, built into the "cap" of the "fountain pen," and has a Q of about 30.

"A Restrictive Practice?"

UNDER this heading in our January, 1954, issue we announced that the question of the supply of valves and cathode-ray tubes was to come under the scrutiny of the Monopolies and Restrictive Practices Commission. It was stated in the official communiqué that the Commission was to "report about both the facts of the matter, and their bearing on the public interest."

In August this year, however, it was announced that the Commission's findings "are now to be a factual report only." All such reports must, of course, be factual, but the significance of this phrase is that it will describe the industry's arrangements, but will not give any views on whether or not they are in the public interest.

The report was received by the Board of Trade on September 17th, and "will be published in due course."

On October 4th the British Radio Valve Manufacturers' Association (B.V.A.)* issued a statement, which we quote in full below, announcing changes in the constitution and trading practices of the Association having effect from September 1st.

"It will be known that the Association abandoned its 'stop list' and allied provisions some years ago and it has now discontinued all arrangements for collective resale price maintenance on the part of the manufacturers. This has been made necessary by the Restrictive

Trade Practices Act which, in effect, prohibits this practice. It will in future be for each individual manufacturer to maintain the prices of his own valves and tubes if he so desires.

"Hitherto 'B.V.A. Prices' have been fixed by agreement of all manufacturers who are members of the Association. This policy has also been abandoned. From knowledge of the structure of the industry, however, and in view of the present period of recession with continually rising costs, it will be appreciated that although prices are no longer to be fixed by agreement it does not follow that the prices of comparable valves and tubes will necessarily vary between one manufacturer and another in the immediate future.

"In coming to the decision to abandon collective fixing of prices, the Association has had in mind that if this practice were to be continued it would in all probability have to be justified in the very near future before the Restrictive Trade Practices Court in the light of the narrow economic criteria set out in the Act. The practice of fixing prices by agreement is not in the present state of the industry of the same degree of importance as it has been in the past or as it may well be in the future.

"Apart from the foregoing the Association is continuing its general policy in the interests of the public, the trade and the industry itself, including its vast field of technical collaboration between the manufacturers, with the Services and in international fields."

* Members of the B.V.A. are: Cossor, Edison-Swan, Ever Ready, Ferranti, G.E.C., Marconiphone, Mullard, Philips and S.T.C.

Continuity of Power Supply

Bridging the Gap Between Mains Failure and the Connection of an Auxiliary Source

IN all essential services normally dependent on power from the public electricity supply, it is customary to have a standby source available for use in case of failure of the mains. This may be a bank of storage batteries or an auxiliary generating plant, but in either case there will be a break in the supply while automatic changeover switches are tripped or the engine is started and run up to speed.

To overcome these difficulties a motor-generator power plant developed by Standard Telephones and Cables in conjunction with Pelapone Engines, Ltd., of Derby, incorporates a heavy flywheel which stores enough kinetic energy not only to start a standby diesel engine but also to drive the loaded a.c. generator

until the engine has developed full power. A magnetically operated clutch between flywheel and engine is arranged to engage when the external power supply is interrupted.

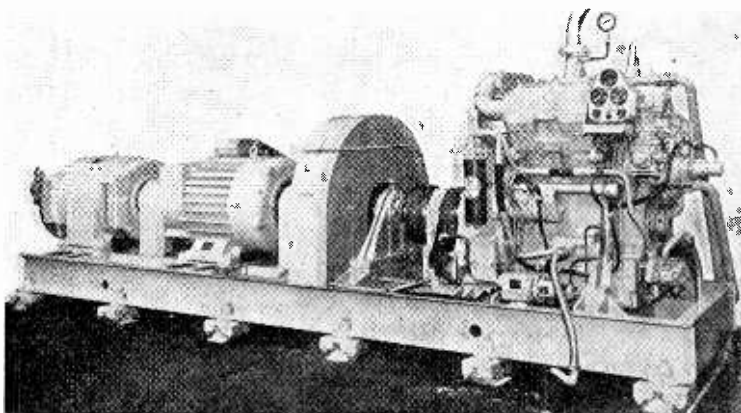

"No break" power plant for telecommunication systems. Rated output 55kVA.

WORLD OF WIRELESS

Organizational, Personal and Industrial Notes and News

NORTHERN service area of the I.T.A. when Emley Moor joins Winter Hill in November.

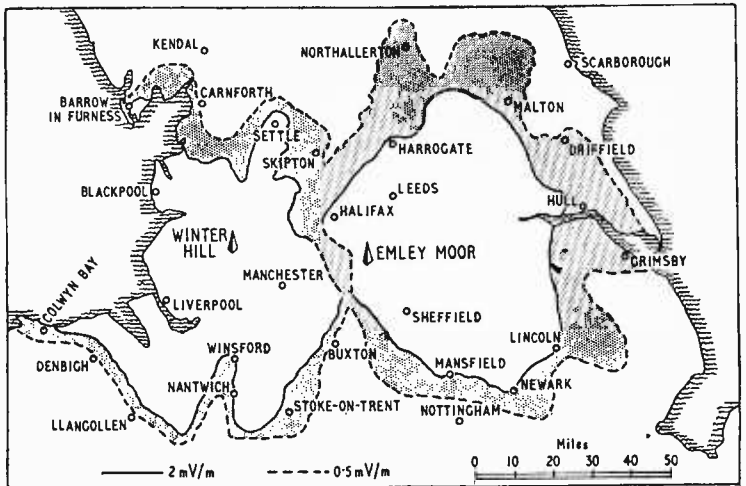

I.T.A. Progress

THE fourth I.T.A. transmitter (on Emley Moor, near Huddersfield, Yorks.) opens on November 3rd—within 14 months of the opening of the Authority's first station.

It will use a directional aerial, vertically polarized, with an e.r.p. varying from 10 to 200 kW—the flat side of the polar diagram being towards the Pennines to avoid undue overlapping of the service areas of the two northern transmitters. It will operate in Channel 10 (199.75 Mc/s vision, 196.25 Mc/s sound).

It is hoped that it will be possible to transmit trade tests on high power for about a week before programmes begin. The present low-power pilot transmissions will continue to be broadcast daily, except on Sundays, until then.

V.H.F. Receiver Response

READERS in south-east England interested in knowing the frequency response of their v.h.f. sound receivers will be pleased to learn that the B.B.C. has introduced standard-frequency test transmissions from Wrotham. They are being radiated each Thursday afternoon from 4.45 until 5.10 by the Third Programme transmitter (91.3 Mc/s). The B.B.C. hopes to maintain the level of tone accuracy within about ± 1 dB after allowing for 50- μ sec pre-emphasis and de-emphasis. The depth of modulation, excluding pre-emphasis, is 30 per cent, with the exception of the frequency marked with an asterisk which is 100 per cent.

The schedule is:—1645-1646, plain carrier; 1646-1648 1kc/s*; 1648-1650, 1kc/s; 1650-1653, half-minute transmissions of each of the following frequencies 50, 100, 440, 1,000, 5,000 and 10,000 c/s; 1653-1703, plain carrier; 1703-1710, as from 1646-1653.

B.S.R.A. Show

THE 1957 convention and exhibition of the British Sound Recording Association will be held in the autumn (September 20th-22nd), instead of in the spring as in previous years, and will again be at the Waldorf Hotel, Aldwych, London, W.C.2.

The Exhibition, which will be similar in general character to the eight previous shows organized by

the Association, will emphasize the technical and engineering aspect of the equipment to be shown.

In addition to providing individual demonstration rooms for exhibitors, there will also be a communal demonstration hall.

“Importing an Instrument”

SINCE the publication of A. J. Reynolds' article under this heading in the October issue the Board of Trade has issued a revised form of application for the Duty Free Licence, which makes that part of the article referring to these licences meaningless.

The new form is in effect designed to make life so difficult for the applicant that he gives up the struggle and pays the duty. Question 8, for example, asks for copies of all correspondence with U.K. manufacturers during the search for an alternative.

Question 9 asks for the precise grounds on which exemption from duty is claimed, and, if superiority of performance is claimed, demands supporting evidence (in duplicate!) which “may be referred to the British manufacturers for their observations.”

The new official attitude goes so far as to refuse duty-free importation of spares for instruments already in the country (and imported duty free) if a “similar” British instrument is now available.

PERSONALITIES

Sir Stanley Angwin, K.B.E., has retired from the chairmanship of the Commonwealth Telecommunications Board which he has held since 1951, and was succeeded on October 1st by Sir Ben Barnett, K.B.E., who recently retired from the Post Office where he was deputy director-general. Sir Stanley, who is 73, was Post Office engineer-in-chief from 1939 until his resignation in 1946 on his appointment as chairman of Cable and Wireless, which he relinquished on joining the Commonwealth Telecommunications Board. He was chairman of the Radio Research Board from 1947 to 1952 and a year later was awarded the Faraday Medal by the I.E.E.

Sir Lawrence Bragg, F.R.S., a director of the Davy Faraday Laboratory of the Royal Institution, will give the third Clerk Maxwell memorial lecture during the 1957 convention on “Electronics in Automation” being organized by the Brit.I.R.E. The lecture will be given on the first day of the convention, June 27th, in the Cavendish Laboratory, Cambridge.

In recognition of "his contributions to the advancement of radio science, and in particular for his long series of notable editorial articles in *Wireless Engineer*," **Professor G. W. O. Howe**, D.Sc., LL.D., Wh.Sch., M.I.E.E., has been elected an honorary member of the British Institution of Radio Engineers. Having been professor of electrical engineering at Glasgow University for 25 years (1921-1946), it is fitting that the proposal for his election should come from the Scottish section of the institution. He becomes the 15th honorary member of the institution, and the fourth elected since the end of the war.

Dr. Balth. van der Pol is due to retire from the directorship of the International Radio Consultative Committee at the end of the year. At the recent C.C.I.R. plenary assembly in Warsaw, **Ernest Metzler**, head of the radio section of the Swiss P.T.T., was elected to succeed him. Dr. van der Pol was appointed director of the C.C.I.R. in 1948, and his term of office was extended by two years to cover the recent plenary assembly. In 1953 he was awarded the Valdemar Poulsen gold medal by the Danish Academy of Technical Sciences for his work on the propagation of radio waves both in theory and practice. Prior to joining the C.C.I.R. he was a member of the board of the Physics Laboratory of the Philips organization in Eindhoven, Holland.

H. E. M. Barlow, B.Sc.(Eng.), Ph.D., M.I.E.E., Pender Professor of Electrical Engineering at University College, London, has joined the editorial advisory board of our sister journal *Wireless Engineer*. Professor Barlow has been a member of the academic staff of the Faculty of Engineering, University College, since 1925. He joined the Telecommunications Research Establishment in 1939, and in 1943 was appointed superintendent of the radio department at R.A.E., Farnborough.

"For their work in originating and developing the Decca Navigator System" **William J. O'Brien** and **Harvey F. Schwarz** have jointly been awarded the Gold Medal of the Institute of Navigation. Mr. O'Brien conceived the system of hyperbolic phase-comparison navigation in the United States in 1938, and with the help of Mr. Schwarz, then of the Decca Record Company, arranged for demonstrations in this country which culminated in its operational use as a mine-sweeping aid in the D-Day landings. There are now Decca chains covering the whole of the British Isles and most of the Western European seaboard.

O. W. Humphreys, B.Sc., F.Inst.P., M.I.E.E., director of the G.E.C. Research Laboratories, Wembley, has been elected president of the Institute of Physics. He has been a vice-president since 1952 and has been chairman of the International Special Committee on Radio Interference (C.I.S.P.R.) for the past three years.

A. J. Brunner, B.Sc.(Eng.), A.C.G.I., D.I.C., A.M.I.E.E., chief engineer of E. K. Cole, Limited, which he joined in 1947, has been appointed an executive director of the company. Before joining Ekco he was at the Ministry of Supply where for several years he held the post of deputy director, radio production. Mr. Brunner is also a director and general manager of Ekco Electronics, Limited.

A. Berkovitch has been appointed manager of Philips' car radio department in place of **A. F. D. Knight**, who has now taken up another appointment within the company's television and radio division. Mr. Berkovitch, who was with Philips for a short time before the war, was for nine years in charge of telecommunications and transport with the International Police Force in Trieste.

J. M. Bedford, A.M.Brit.I.R.E., until recently chief engineer of the radio section of Igranic, Ltd., has joined the research and developing department of Parmeko, Ltd., manufacturers of transformers, transducers and magnetic amplifiers.

T. C. Isaac, who joined Ambassador Radio and Television, Limited, as chief engineer in 1953, has been appointed technical director of the company. Before joining Ambassador he was chief engineer of Mains Radio-Gramophones, of Bradford, the manufacturing company for Radio Rentals, Limited. **K. H. Yandell**, who joined Ambassador this year, has also been appointed to the board as sales director. He has previously been with Philco, Regentone and R.G.D.

C. G. Allen, who has been with McMichael Radio for over 33 years, has ceased to be a director and sales manager of the company. He hopes to retain a connection with the radio industry.

OUR AUTHORS

H. de Laistre Banting, who writes on the design of multi-standard television receivers in this issue, has been in charge of the television department of the Société Belge de Télécommunications in Brussels since 1954 where he has been concerned with the development of receivers for the Benelux countries. Before going to Belgium he was for several years in the research department of Murphy Radio, having previously been with Bush Radio which he joined in 1941.

J. D. Smith, author of the article on recording characteristics, graduated in 1950 at Bristol University with second class honours in physics. After two years graduate apprenticeship with the General Electric Company at their radio and television works, he joined the staff of the company's applied electronics laboratories. His interest in sound reproduction is purely a leisure-time pursuit.

P. Tharma, who describes a transistor receiver in this issue, joined the transistor section of Mullard's valve measurement and applications laboratory last year. He was educated at Ceylon Technical College where he received a B.Sc. honours degree in engineering in the external examination of the University of London. On coming to this country he received his telecommunications training with the G.P.O.

OBITUARY

As a result of a motoring accident, **Roland Harris Dunn**, B.Sc., A.M.I.E.E., head of an advanced development section of the Telephone Division of Standard Telephones and Cables, died on September 7th at the age of 49. After graduating at Manchester University he was for a short while with B.I. Callender's Cables before joining the engineering staff of S.T.C. in 1930. In recent years he has specialized in various branches of electronics with particular reference to telemetering.

Maurice C. Jones, A.M.I.E.E., general manager of Gardners Radio Limited, of Somerford, Christchurch, Hants, for the past ten years, died in August aged thirty-nine. Before joining Gardners he was in the Telecommunications Research Establishment at Langton Matravers and later at Malvern.

IN BRIEF

As was anticipated, **television licences** reached the six million mark during August. The month's increase was 64,820, bringing the total at the end of the year to 6,044,330. The total number of sound receiving licences at the end of the year was 8,038,062, including 307,082 for car radio. The overall total of broadcast receiving licences current in the United Kingdom at the end of August was, therefore, 14,389,474.

The date of the Radio Industry Council's proposed **Scottish Radio Show** has been announced. It will be held at the Kelvin Hall, Glasgow, from May 22nd to June 1st next year. Although this is the first show to be organized in Scotland by manufacturers since 1935, the Scottish Radio Retailers' Association has held two Glasgow shows since the war.

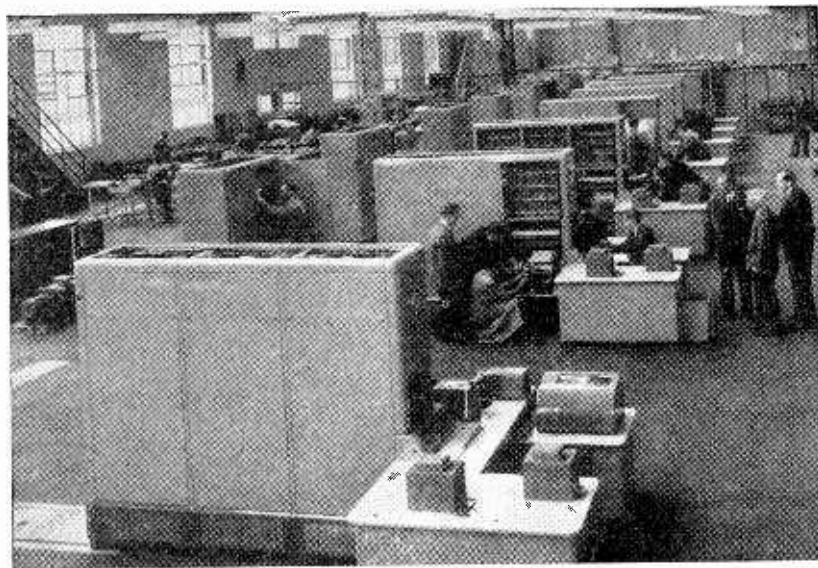

PRODUCTION LINE at Ferranti's new Manchester works where Pegasus (shown here) and Mercury computers are being manufactured in quantity.

An electronic instruments exhibition is being staged by E.M.I. Electronics, Ltd., at the Royal Hotel, Woburn Place, London, W.C.1, from November 28th to 30th. In addition to some one hundred instruments being shown and demonstrated, it is also proposed to show computers for machine tool control in operation. The exhibition will be open from 10 a.m. to 6 p.m., and admission is by ticket obtainable free on written application to E.M.I. Electronics, Ltd., Hayes, Middlesex.

Membership of the Brit. I.R.E. increased during the year ended March 31st by 310, bringing the total to 5,392.

The R.I.C. panel of judges, on which Arthur Clarkson (G.E.C.) recently replaced W. M. York (E. K. Cole), is considering articles already submitted for the 1956 premiums for technical writing. Articles should be submitted to the R.I.C., 59, Russell Square, London, W.C.1, before December 31st.

A short course of evening lectures on the microwave behaviour of ferrites begins on October 16th, at Sir John Cass College, Jewry Street, Aldgate, London, E.C.3. The fee for those residing in the administrative county of London is £1.

Two courses on transistors have been organized by the Borough Polytechnic, Borough Road, London, S.E.1. The first, covering basic principles, began on October 9th, and the second, on special applications, begins on January 15th. The lectures will be given in the afternoon and repeated in the evening. The fee for each ten-lecture course is 25s.

Demonstrations of "hi-fi" equipment and stereophonic tapes are being given by Classic Electrical Co., Ltd., at the Croydon Civic Hall on November 26th and 27th. On the first day demonstrations will be given from 1.0-2.0, 6.30-8.0 and 8.30-10.30, and on the second day in the evening only.

S.I.M.A. Officers.—At this year's annual general meeting of the Scientific Instrument Manufacturers' Association, G. A. Whipple, M.A., M.I.E.E., F.Inst.P., chairman and managing director of Hilger and Watts, was installed as president. P. Goudime, of Electronic Instruments, was elected vice-president and the following as new members of the council: F. W. Dawe (Dawe Instruments), P. J. Ellis, O.B.E. (Pullin), J. M. Furnival, M.B.E. (Marconi Instruments), D. F. Newstead (Rank Precision Industries), J. A. Stafford (Taylor, Taylor and Hobson), W. H. Storey (Unicam Instruments) and N. Trepte (Griffin and George).

London Computer Group has been formed to enable people with different professional interests to examine, through study groups, common problems in computer use. Membership is open to anyone with an interest in computers. The joint honorary secretaries are at 19A, Coleman Street, London, E.C.2 (Tel.: Monarch 7822).

T.E.M.A.—The annual report of the Telecommunication Engineering and Manufacturing Association, of which H. Faulkner is director, deals largely with Post Office matters of policy and development as they affect the telecommunications manufacturing industry. In the section dealing with education and training in the industry it is announced that the Association is preparing a careers handbook for publication later this year.

Amateur Exam. Results.—Of the 518 candidates who sat for the radio amateurs' examination conducted by the City and Guilds of London Institute in May, 458 (88.4 per cent) were successful. Four of the candidates were blind and two bedridden; for these special arrangements were made for the tests to be taken at home.

Instruments—measurement and control—and components associated with them are classified under some 2,000 headings in the buyers' guide section of the 1956 edition of "The Instrument Directory" issued by *Instrument Practice*. The 244-page directory includes lists of manufacturers, trade names and industrial associations.

The annual report of the Institute of Physics records that during the past year the membership increased to over 5,000. The Institute's recently established graduateship examination was taken in four centres by 54 candidates, of whom only 11 passed.

BUSINESS NOTES

The Mervac Printer, an exposing unit produced by Grant Production Company (4, Rathbone Place, Oxford Street, London, W.1), can be used in a dual rôle in the production of printed circuits. It can produce the film negative from the original wiring diagram, and also print the circuit on the copper laminate. The company also provides a service for the production of printed circuits to manufacturers' requirements.

Webcor (Great Britain), Ltd., formed last year as a subsidiary of the American Webster-Chicago Corporation to market in this country record players and receivers, has temporarily suspended operations. Enquiries should be sent to Belcher (Radio Services), Ltd., 59, Windsor Road, Slough, Bucks. (Tel.: Slough 24501.)

The resistance wire Evanohm, to which "Diallist" referred in September, is of American origin but is obtainable in this country from Gilby-Brunton, Ltd., 47, Whitehall, London, S.W.1.

A 3½-acre site has been chosen at Harlow, Essex, for the erection of a group of buildings to accommodate the recently-formed **Siemens-Ediswan Research Laboratories** of which Dr. G. W. Sutton is director. Until the new buildings are occupied, laboratory space is being provided at the companies' works at Brimsdown, Woolwich and Blackheath.

Sound reinforcement equipment and multi-language interpretation facilities were provided by **Tannoy** for each of the 235 seats at the recent Suez Conference in Lancaster House, London.

The **Ekco** portable television receiver, which also incorporates v.h.f. sound, is being installed in the chauffeur-driven cars operated by **Daimler Hire, Limited**, London. Owing to the screening of the car's metal body and the limitation of space in the car, the receiver's telescopic built-in aerial has been replaced by one mounted externally. The screen can be seen only in the rear compartment.

Communal television aerial systems have now been installed in several Devon towns and at **Sheringham, Norfolk**, by **J. S. Fielden, Limited**. Work on other systems for the West Country, Lancashire and Cumberland is due to start this year.

Several radio applications of "Stick-a-seal" self-adhesive polyurethane foam are suggested by the suppliers, **Sealdraught, Limited**, of Chandos House, Buckingham Gate, London, S.W.1. Among them, loudspeaker mounting and sealing for glass panels of television sets. The material is available in three standard thicknesses (1/8th, 3/16th and ¼ inch) and a variety of widths up to 19 inches.

The production of **Ardente** hearing aids and miniature components has been transferred to the company's new factory at 8-12, **Minerva Road, North Acton, London, N.W.10**. (Tel.: Elgar 3923.)

Bel Sound Products Company, of Marlborough Yard, London, N.19, announce that they can supply p.t.f.e. machined from rod to any shape.

Welwyn Electrical Laboratories, Limited, component manufacturers of **Bedlington, Northumberland**, are now making thermistors.

The new offices and enlarged factory of **Partridge Transformers, Limited**, at **Roebuck Road, Tolworth, Surrey**, were recently opened by Mrs. V. R. Partridge, widow of the founder of the company.

Willesden Transformer Company, Limited, are now occupying a further 15,000 square feet at their new factory at **Manor Park Road, Harlesden, London, N.W.10**. (Tel.: Elgar 5445.)

Direct TV Replacements, of 134-136, **Lewisham Way, New Cross, London, S.E.14**, have been appointed distributors of **Pinnacle valves**.

Philips' new north-west regional headquarters at 20, **Cannon Street, Manchester**, include a specially-designed demonstration room where it is planned to hold regular gramophone recitals.

EXPORT NEWS

Communications equipment, including transmitters, receivers, aerials, power plant and ancillary gear, for **Iran's Police Forces** is to be installed by **Redifon, Limited**. The contract, valued at nearly £500,000, also calls for the setting up of a radio training school.

Loudspeaker Units.—The first consignment of **Goodmans'** recently-introduced "pressure" units—**Trebas** and **Midax**—was shipped to the United States at the end of August.

It was stated in a note on television receivers for **Bangkok** in this section last month that the 625-line standard was employed. Although this was originally adopted **Thailand** now operates on American standards.

A report on the market for sound and television receivers in Italy has been prepared by the **Export Services Branch of the Board of Trade**. It concludes "If United Kingdom manufacturers wish to arrest the decline in their position and fight back against the commanding position gained by Germany in the last four years they will need to undertake aggressive sales publicity and offer, at competitive prices, sets that incorporate all the gadgets that have become virtually standard in Continental sets and pay particular attention to the rising popularity of f.m."

British manufacturers of domestic and marine radio equipment may be interested to know that **Gough Industries Inc.**, a leading firm of wholesalers and distributors, of 819, **East First Street, Los Angeles**, has approached the **British Consulate General** with a proposal to help firms to sell their products in Southern California, Arizona, Nevada, Utah and Hawaii. The plan is that the company would receive samples and arrange for them to be exhibited to selected distributors within the Gough organization.

Electronic Equipment.—**Feedback Control, Inc.**, 899, **Main Street, Waltham, Mass., U.S.A.**, would like to represent United Kingdom manufacturers of electronic (other than communications) equipment who are not already represented in the U.S.A. They would act as representatives and/or a servicing organization throughout the United States.

Television Receivers.—**Tebag AG.**, **Lavaterstrasse 66 (Postfach), Zurich 27, Switzerland**, are interested in representing United Kingdom manufacturers of television sets. The Swiss standards are 625 lines, negative vision modulation and f.m. sound.

Radiogramophones.—The **Pentron Corporation**, 777, **S. Tripp Avenue, Chicago 24, Illinois, U.S.A.**, is interested in distributing good quality radiogramophones manufactured by British firms. They should cover the m.w. band as well as v.h.f./f.m.

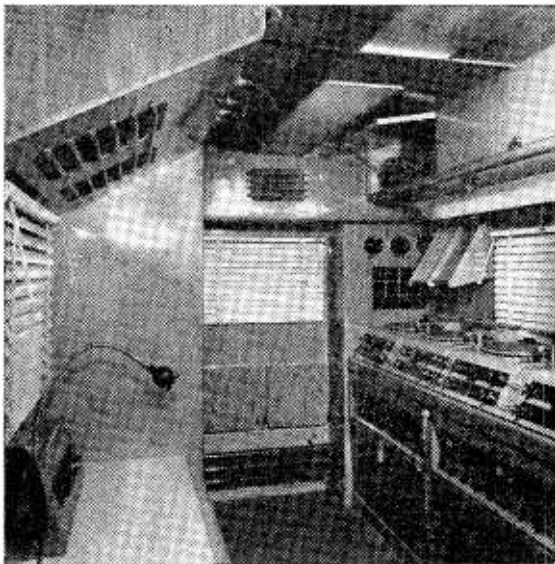

CONTROL ROOM in the mobile studio recently brought into service by the B.B.C. for outside sound broadcasts. Provision is made for recording and reproducing programmes and sound effects, and a receiver is installed to pick up transmissions from commentators equipped with walkie-talkies. Two Mullard transmitter-receivers are provided for linking the studio to the nearest B.B.C. centre when Post Office lines are not available.

Disc Recording Characteristics

STANDARDIZATION AT LAST ? SOME NOTES ON B.S. 1928 : 1955

By J. D. SMITH, B.Sc.

THERE has in the past been much controversy over the subject of recording characteristics. Numerous writers have quoted characteristics, often with considerable divergencies of opinion. Indeed the very mention of "recording characteristic" has been sufficient to unleash a spate of correspondence in the technical Press. In view of this it is very surprising that the revised British Standard 1928:1955*, issued over a year ago, has provoked almost no comment other than brief notices of its existence. Can it be that the new Standard settles once and for all every possible argument on the subject, or is the recording-characteristic-conscious section of the public largely unaware of its existence? Be this as

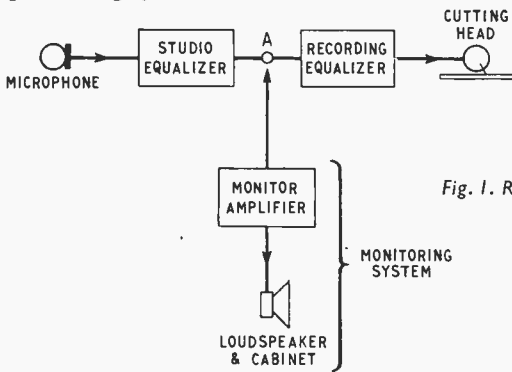
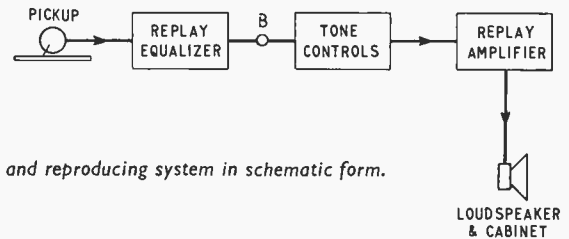

Fig. 1. Recording and reproducing system in schematic form.

monitor chain consisting of amplifier, loudspeaker and listening room, it has the balance and quality that the manufacturer desires: presumably a subjective judgment. To prevent adjacent grooves from overlapping at low frequencies, and to improve signal/noise ratio at high frequencies, this electrical signal is equalized to a known recording characteristic before being fed to the cutting head. During replay the output from the pickup is fed via an equalizer having a response which is the inverse of the recording characteristic, so that, save for any deficiencies in the system, the signal at B will be a replica of that at A. Then, if the same monitor chain as before were connected to B, the sound would be exactly as



it may, it is perhaps worth while to examine this new characteristic, in view of the fact that the specification or its equivalent is now being adopted by many record manufacturers in this country and abroad.

Limitations of Standardization.—B.S. 1928 covers most aspects of recording and reproducing gramophone records and transcription recordings on discs. Speeds of rotation and various dimensional features of discs and reproducing equipment are specified. This much is relatively straightforward but the question of standardizing recording characteristics is very much more involved as the committee responsible for the Standard have been at pains to point out in an appendix.

The nature of these difficulties becomes apparent on examining Fig. 1, in which a complete recording and reproducing system is shown schematically. The studio equalizer is adjusted to compensate for studio and microphone deficiencies and to obtain the desired balance between high and low frequencies. The electrical signal at point A is then such that when reproduced by means of a specified

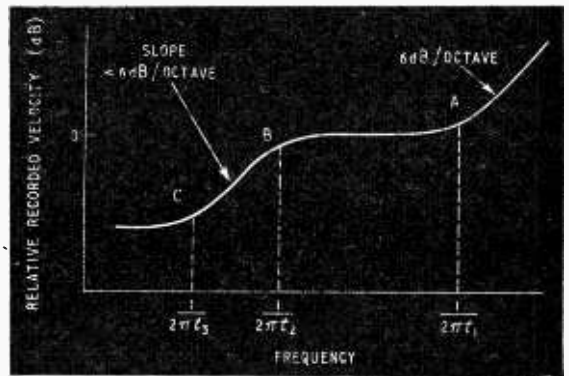

Fig. 2. General form of standard recording characteristic.

manufacturer intended. In practice the signal at B is reproduced by a different system, usually incorporating yet another equalizer, the "tone controls," by which the listener introduces his personal preferences. The sound as finally reproduced may, therefore, differ from what the manufacturer had intended, but it does so in a manner determined by the listener.

Now if a second manufacturer were to make a record of the same performance he would, in general, use a different monitor system and would equalize to produce a balance which he regarded as satisfactory. The signal at A would, therefore, differ from that produced by the first manufacturer at that point. The same is true of the replayed signal at

* British Standard 1928 : 1955. "Gramophone Records, Transcription Disk Recordings and Disk Reproducing Equipment." Revised May, 1955. Obtainable from British Standards Institution, 2, Park Street, London, W.1.

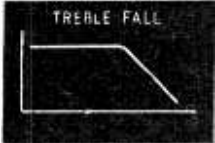
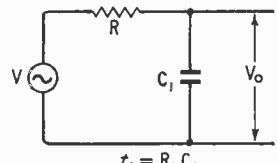

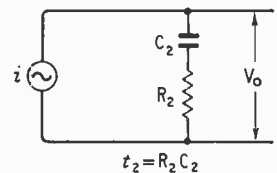

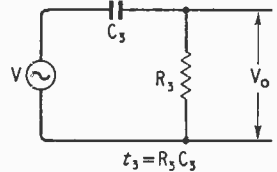

TABLE 1.

Time constant	Coarse groove	Fine groove
Treble rise t_1	50 μ sec	75 μ sec
Bass fall t_2	450 μ sec	318 μ sec
Bass rise t_3	3180 μ sec	3180 μ sec

B, provided that matched recording and replay characteristics be used (though not necessarily similar to those used in the first case). This signal at B would have to be reproduced by the second manufacturer's monitor system in order to obtain the sound as intended by him.

Thus the whole picture becomes somewhat confused and all that standardization can do at present is to specify recording and replay characteristics which could be adopted by all manufacturers. This ensures that the listener can with certainty obtain at point B in his reproducing chain the electrical signal intended by the manufacturer. This the British Standard does and no more. Having done this there are still the differences between the

Fig. 3. Basic passive networks comprising a replay equalizer.

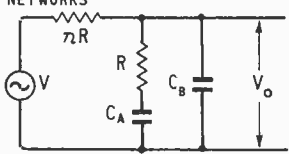
FUNCTION	NETWORK	TRANSFER FUNCTION
	 <p>$t_1 = R_1 C_1$</p>	$\frac{V_o}{V} = \frac{1}{\sqrt{1 + 4\pi^2 f^2 t_1^2}}$
	 <p>$t_2 = R_2 C_2$</p>	$\frac{V_o}{i R_2} = \sqrt{1 + \frac{1}{4\pi^2 f^2 t_2^2}}$
	 <p>$t_3 = R_3 C_3$</p>	$\frac{V_o}{V} = \frac{1}{\sqrt{1 + \frac{1}{4\pi^2 f^2 t_3^2}}}$
	<p>OVERALL TRANSFER FUNCTION</p> $\sqrt{\frac{1 + \frac{1}{4\pi^2 f^2 t_2^2}}{\left[1 + \frac{1}{4\pi^2 f^2 t_1^2}\right] \left[1 + \frac{1}{4\pi^2 f^2 t_3^2}\right]}}$	
<p>COMBINED NETWORKS</p> $\tau = \frac{t_3 - t_2}{t_2}$ $RC_A = t_2$ $RC_B = \frac{t_1 t_3}{t_3 - t_2}$		<p>TRANSFER FUNCTION AS FOR CASCADED NETWORKS</p>

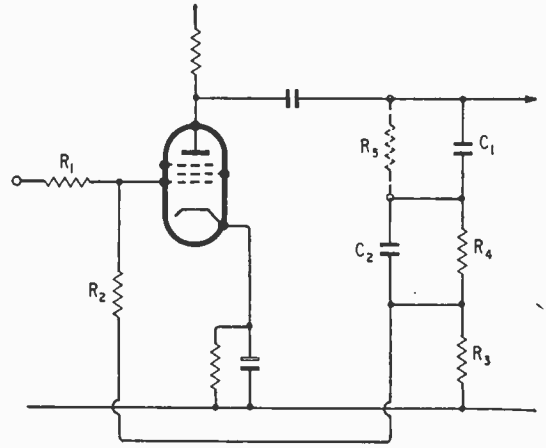

Fig. 4. Equalizer employing negative feedback. The resistor R_5 (shown dotted) is normally omitted, but may be included if necessary to limit the low-frequency boost.

various manufacturers' monitor systems: as pointed out in the Standard, it would be highly desirable to standardize these but at present this is impracticable. The manufacturer's preferences in the matter of balance and so forth must be regarded as part of the actual performance and as such may not be subjected to standardization; the same is true of adjustments made by the listener.

The above discussion seems to suggest that there are still many loopholes in the Standard. There is perhaps some truth in this but nevertheless it is a great step forward to have two characteristics, one for "coarse groove" and one for "fine groove" recordings, clearly and simply defined so that the listener is no longer at the mercy of opinion in this matter. It is certainly to be hoped that all manufacturers will adopt them.

The New Standards.—

The new standard characteristics are very conveniently defined in terms of the time-constants of equalizing networks. Fig. 2 shows diagrammatically a recording characteristic. There are three portions to this curve: at A there is a treble rise defined by time-constant, t_1 , so that at high frequencies the curve rises at a rate of 6 dB per octave. At B

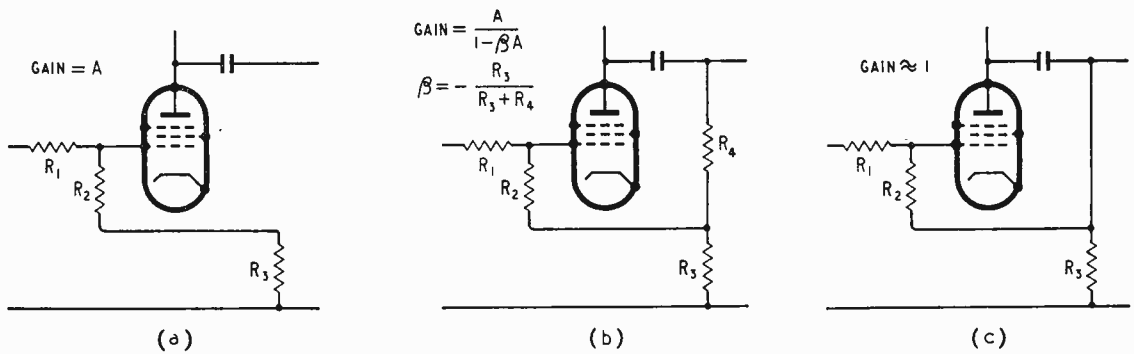

Fig. 5. Equivalent circuits of Fig. 4 at (a) low, (b) mid-band, and (c) high frequencies.

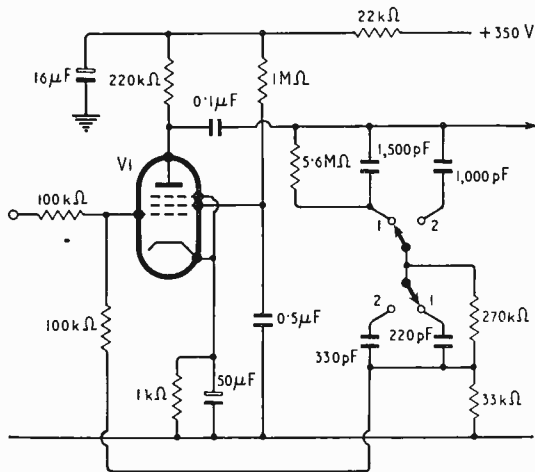

Fig. 6. Complete equalizer for B.S.S. 1928 : 1955 characteristics. V1 may be Z729, EF86, 6BR7, etc. Mid-band gain approx. 10. Switch positions: 1—B.S.S. Coarse Groove, 2—B.S.S. Fine Groove.

there is a bass fall and a second time-constant, t_{22} , defines this. At low frequencies the response does not fall away indefinitely because a bass rise of time-constant, t_{33} , is included. Table 1 gives the values of the time-constants as set out in the Standard.

Replay Equalizers.—A replay equalizer could be constructed using passive networks chosen to give the appropriate time-constants, remembering that a rise in recording characteristic must be matched by a fall in replay characteristic. The three networks must be cascaded in such a manner that they do not interact one with another; alternatively a single passive network incorporating all the necessary time-constants may be used. Such networks are shown in Fig. 3.

It is preferable, however, to use a valve with selective feedback to provide equalization and to incorporate the time-constants in the feedback loop. Fig. 4 shows such a circuit. In Fig. 5 are shown the three circuit conditions at low, mid-band and high frequencies. Notice that, as Fig. 5(a) shows, the gain at low frequencies, where maximum boosting is required, is limited to that available from the valve. In this way the required bass fall is provided without actually including a further time-constant: the ratio of the effective time-constant of this bass

fall to that of the bass rise is the ratio of the maximum gain of the stage to that at mid-band, where a moderate amount of feedback is applied as shown in Fig. 5(b). If in a particular circuit this ratio is too great, R_5 may be included to provide a small amount of feedback at low frequencies. In a similar way there is a limitation of the high-frequency attenuation when the condition of Fig. 5(c) is reached, the gain then being unity (if $R_1=R_2$). However, this undesired limitation is not serious in a properly designed circuit. The actual time-constants are given by $C_1(R_3+R_4)$ for bass rise and C_2R_1 for treble fall.

Fig. 6 shows a circuit with suitable component values. Note that the switch may have as many positions as desired so as to incorporate equalization for older recordings. The load on this stage should not be heavier than 1 megohm or the available gain will be reduced and full bass boost will not be provided. If the stage must be more severely loaded it is possible by reducing R_2 to obtain the necessary bass boost at the expense of overall gain.

DO YOU KNOW?

THE length of the dipole for a Band II aerial?

The relationship between m.k.s. and c.g.s. units?

The address of the International Amateur Radio Union?

The base connections for a LN309 valve?

What external resistance is needed in series with a 25-volt meter (1,000 ohms/V) to read voltages up to 500?

If a licence is required to operate a transmitter for the control of a model?

The answers to these and innumerable other technical and organizational questions can be found in the 1957 *Wireless World* Diary—the *vade mecum* of all who have an interest in radio.

The Diary, now in its thirty-ninth year of publication, includes, in addition to the usual week-at-an-opening diary pages, an eighty-page reference section. It is obtainable from booksellers and news-agents, price 6s (leather) and 4s 3d (Rexine) including purchase tax. Overseas prices are, respectively, 5s and 3s 6d, plus 2d postage.

“Full-Range Electrostatic Loudspeakers.”—The third line from the bottom of column 2 of p. 486 of the October issue should read “. . . $C = \text{equivalent capacitance} = 4t_r^2/K$, where $K = \text{motional stiffness. . . .}$ ”

Transistor D.C. Amplifier

LOW-NOISE CIRCUIT FOR MILLIMICROAMPERE SIGNALS

By D. M. NEALE* and FRANCIS OAKES†

An amplifier is described which provides a current gain of 1,000; power gain, 45 dB; zero stability, 0.001 μ A (10 μ V); and a frequency response extending beyond 20 kc/s. A push-pull grounded-emitter stage is followed by a push-pull grounded-collector stage. A fifth transistor in a negative feedback loop limits the effects of collector leakage current variations, and by stabilizing the first-stage collector voltage restricts the effect of transistor noise. The amplifier was developed for use with barrier-layer photocells at very low light intensities. It has excellent linearity and can also be used in conjunction with a semiconductor diode to provide a high-impedance low-level r.f. voltmeter usable up to frequencies limited only by the performance of the diode.

FOR the amplification of small direct currents, a battery-fed transistor amplifier offers several advantages. Warm-up time is greatly reduced and problems of supply voltage stabilization are virtually eliminated. The effects of low-frequency noise¹ and the rapid rise of leakage current with rise in temperature can be controlled by careful design so that, where a medium input impedance is required, the transistor-operated amplifier provides a better performance than a thermionic amplifier.

Whereas it is possible to eliminate the effects of temperature by carefully matching transistor characteristics and also by applying negative feedback, there seems to be no way of countering the effects of noise. The simple circuit of Fig. 1 was therefore used to find how small an input current could be definitely distinguished from noise. It was soon found that, as has been reported before², there is a marked increase in semiconductor noise at higher collector voltages. A collector voltage of at least 0.2 V is of course required to make the transistor operate in the high-alpha region, but it seems that the noise remains substantially constant until the collector voltage exceeds 1.0 V.

With collector voltages between these two limits, the noise fluctuations were observed when a sensitive galvanometer was used as a balance indicator. With Mullard OC71 transistors, fluctuations due to noise were equivalent to about 0.001 μ A at the input. Since a comparable stability is not readily produced in a thermionic amplifier of comparable input impedance (5 to 10 k Ω), an effort has been made to reduce to an insignificant level the drift due to other causes.

The most difficult part of the design appeared to be that of keeping the collector-emitter voltage, V_{ce} , in the range 0.2-1.0 V over a reasonable range of ambient temperatures. Using a push-pull grounded-emitter input stage and collector load resistances of the order of 20 k Ω , changes in collector leakage current limited the range of satisfactory operation without stabilization to about 20°F, e.g. 60°-80°F.

The standing current in a transistor stage may be stabilized³ by the insertion of a resistance in the emitter circuit. The resistance provides negative feedback restricting the variations in the d.c. component of the collector current. Its effect on the a.c. component is usually minimized by the provision

of a bypass condenser. In a single-ended d.c. stage, this type of stabilization offers no advantage, since drift and gain are reduced in the same proportion. In a push-pull stage, however, a common emitter resistance provides stabilization against the effects of in-phase current changes due to leakage current variations, whilst making no reduction in the gain so far as push-pull signals are concerned.

For the type of circuit shown in Fig. 2 it can be shown³ that the stability factor S is given by

$$S = \frac{dI_c}{dI_{c0}} = \frac{1 + R_B/R_E}{1 + (1 - \alpha) R_B/R_E}$$

In order to keep V_{ce} substantially constant, a low

* Ilford, Ltd.

† Ferguson Radio Corporation

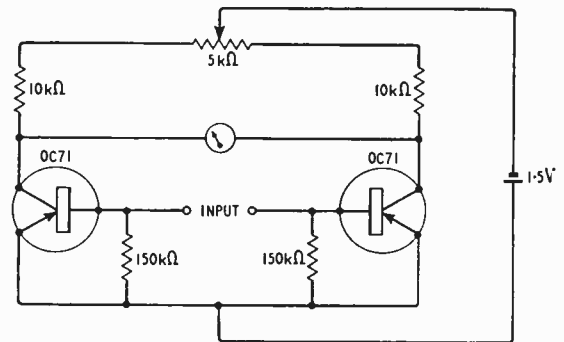

Above: Fig. 1. Simple push-pull amplifier circuit

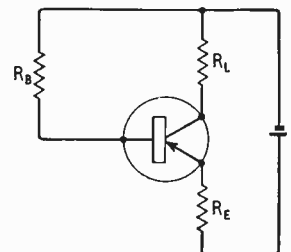

Right: Fig. 2. Stabilized single-ended amplifier.

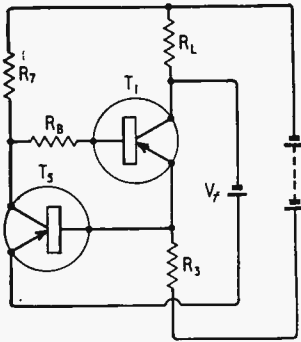
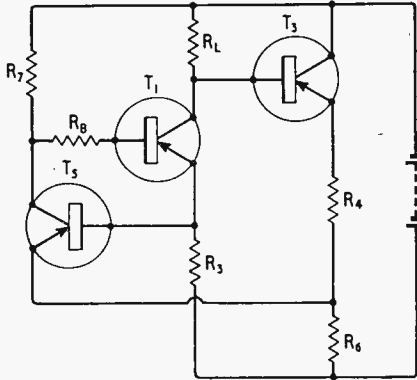

Fig. 3. Addition of a transistor (T_5) to provide amplified feedback.

Below: Fig. 4. Modification of circuit of Fig. 3 to eliminate the separate stabilizing battery.



value of S is required. The above equation shows that S falls to unity when $R_B \ll R_E$. Since R_B must be kept high in order to avoid unnecessary shunting of the input signal, however, a low value of S necessitates a high value of R_E . As the collector leakage current passes also through R_B , the voltage drop across R_E reduces V_c and largely neutralizes the stabilizing action provided.

A more useful criterion for design is the collector-emitter slope impedance, dV_c/dI_{c0} . Assuming limiting values of V_c and I_{c0} of 0.8 V and $16\mu A$ respectively, the highest acceptable value of $-dV_c/dI_{c0}$ is 50 k Ω . The value realized in a given circuit is given, using conventional symbols, by

$$\frac{dV_c}{dI_{c0}} = \frac{dI_c}{dI_{c0}} \cdot \frac{dV_c}{dI_c}$$

$$= -S \left(\frac{R_E}{\alpha} + R_L \right) + \frac{R_E}{\alpha}$$

If $R_E \gg R_B$ and $R_E \gg R_L$,

$$S \approx (1 + R_B/R_E)$$

and $\frac{dV_c}{dI_{c0}} \approx - \left(1 + \frac{R_B}{R_E} \right) (R_E + R_L) + \frac{R_E}{\alpha}$

$$\approx \frac{R_E}{\alpha} - (R_B + R_L)$$

Hence, to obtain low values of dV_c/dI_{c0} with reasonable values of R_L , it is necessary to put $R_B \gg 3R_L$ and $R_E \approx \alpha R_L$. This high value of R_E results in an inconveniently high battery voltage which must, to provide a satisfactory value of V_c , have high stability.

Although simple forms of negative feedback are of little use when the collector voltage must be stabilized within narrow limits, good results may be obtained

by using an additional transistor to apply amplified feedback.

Fig. 3 is the schematic circuit of an arrangement of this type. T_1 represents the transistor to be stabilized, T_5 the transistor used for applying an amplified control signal to the base resistor, R_B , of T_1 . If the collector current of T_1 increases, the reduction in collector-emitter voltage of T_1 is transferred by the feedback battery, V_f , to increase the emitter-base potential of T_5 . Any such increase in emitter-base potential results in a large increase in base current in T_5 , limited only by the internal base and emitter resistances. The increased base current in T_5 in turn produces a large increase in the collector current of T_5 , so increasing the voltage developed across R_7 and reducing that across R_B . In consequence, the base current of T_1 is substantially reduced, enabling the collector current through R_L to be maintained practically constant. It is fortunate that the effect of a temperature rise of T_5 serves to assist the temperature compensation applied to T_1 . Since the emitter-base potential of T_5 is very small so long as a positive base current is flowing, the collector voltage of T_1 is stabilized at the voltage of the battery V_f .

The additional battery, V_f , was eliminated in the final amplifier by modifying the circuit of Fig. 3 to that shown in Fig. 4. The transistor T_3 represents the grounded-collector stage which follows the grounded-emitter transistor T_1 . As the emitter-base potential of T_3 is very small, the potential of the emitter of T_3 is effectively the same as that of the collector of T_1 . If a relatively high battery voltage is used, e.g. 13.5 volts, 1 volt may be dropped across R_4 , whilst at least 90% of the collector excursion of T_1 is still developed across R_6 . The circuit therefore works in the same way as Fig. 3, stabilizing the collector-emitter voltage of T_1 to the voltage dropped across R_4 .

The circuits shown in Figs. 3 and 4 provide a high degree of negative feedback not only for variations of collector current due to changes in the collector leakage current, I_{c0} , but also for changes in collector current due to the amplification of intentionally introduced signal currents fed in at the base of T_1 . In the complete push-pull amplifier, however, the emitter circuit resistors R_S and R_6 are common to both transistors in each stage. It follows, therefore, that push-pull signal currents will cancel in these resistors, whereas the effect of leakage currents will be additive.

A circuit developed on these principles is shown in Fig. 5. It will be seen that a single transistor T_2 is used to control the standing base currents of the transistors T_1 and T_2 in the first stage. At any given temperature the output indication for zero input current may be made independent of source impedance by a simple setting-up procedure. The input terminals are first short-circuited and P_s is adjusted to set the output meter to zero. The input terminals are then open-circuited and P_c is adjusted to correct any consequent shift in the zero. Provided the characteristics of T_1 and T_2 are reasonably well matched, the setting of P_c produces negligible effect on the zero for short-circuited input.

Algebraic analysis of the final circuit leads to cumbersome expressions which cannot be simplified without sacrificing accuracy. The slope resistance dV_c/dI_{c0} was therefore established experimentally,

and found to be of the order of 2 kΩ. This represents an improvement by a factor of 15 over the circuit of Fig. 2.

It was found that the short-circuit zero was commendably stable over the temperature range 50° to 85°F. The open-circuit zero varied considerably however, because the leakage current, internal base- and emitter-resistances of the transistors T₁ and T₂ vary with temperature in such a way that a setting of the potentiometer P_c which is satisfactory at one temperature is not satisfactory at another. Some means was sought whereby the open-circuit and short-circuit zero could be made coincident at two points in the ambient temperature range, with a reasonable agreement in between.

Reversal of the sense of P_c occurs when the collector-base voltage of T₅ falls sufficiently to equal the base-emitter voltages of T₁ and T₂. Under these conditions the base currents of T₁ and T₂ become zero and their collector currents are given by

$$I_c = (1 + \alpha') I_{c0}$$

With representative values of α' , I_{c0} , and internal base and emitter resistances, it may be deduced that the base-emitter voltage amounts to some

hundred millivolts. At temperatures higher than that of this special case, the collector-base voltage of T₅ will become smaller than the base-emitter voltages of T₁ and T₂. The base currents of T₁ and T₂ are then reversed and it is therefore to be expected that the sense of P_c will be reversed also; whereas a reduction of base resistance of T₁ increases both base and collector currents at moderate ambient temperatures, at higher temperatures it increases the negative base current and so reduces the collector current.

In the final amplifier circuit, shown in Fig. 6, this reversal of sense of P_c is used to provide compensation for the effects of temperature on the open-circuit zero. A further potentiometer P_b is used, the sense of which is not reversed by temperature effects. The slider of this control is returned to the emitter of T₅ which is at a potential a few millivolts positive relative to the emitters of T₁ and T₂. The addition of P_b makes it possible to use a setting of P_c which provides temperature compensation and which at the same time allows the short-circuit and open-circuit zeros to be made coincident. This is done without seriously reducing the temperature stabilization provided by T₅.

The optimum setting of P_c is deduced by plotting (with open-circuit input) the meter current versus ambient temperature for various combinations of settings of P_c and P_z. Coincidence of open-circuit and short-circuit zeros is effected by adjusting P_b according to the procedure described above in connection with Fig. 5.

When the three controls P_b, P_c and P_z are adjusted to their optimum positions, very fair temperature compensation is provided over the ambient temperature range 55° to 85°F and, as shown in Fig. 7, a reasonable coincidence is main-

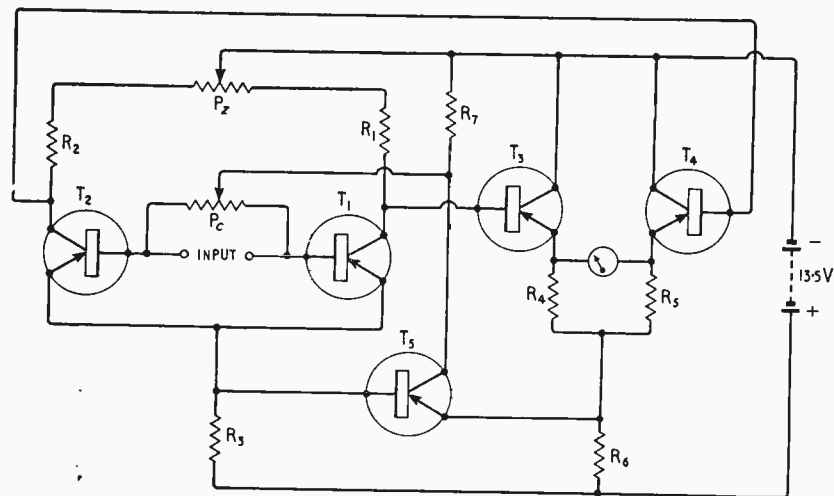

Above: Fig. 5. Amplifier with zero adjustments to make output for zero input current independent of source of impedance.

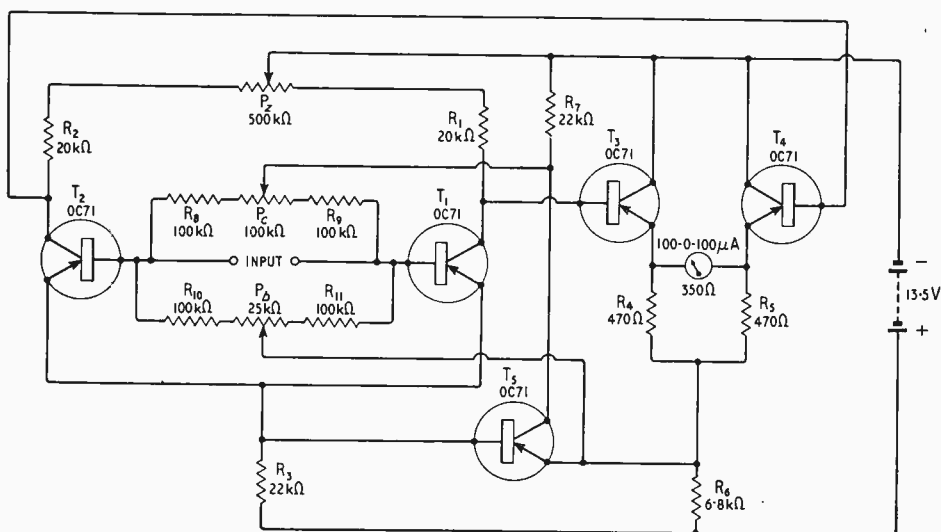

Fig. 6. Final circuit with additional compensation for the effect of temperature on the zero setting.

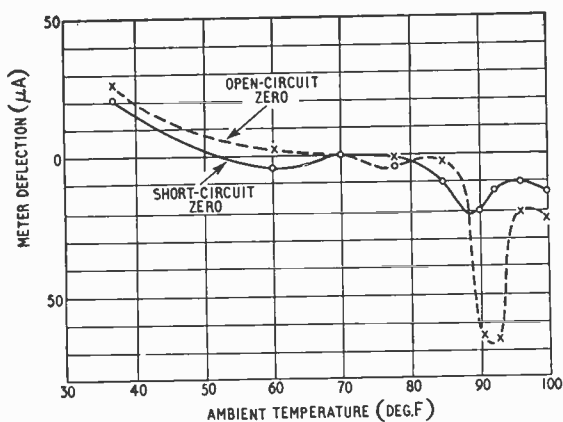

Fig. 7. Measured variation of zero setting with temperature in the circuit of Fig. 6.

tained over this range between the open-circuit and short-circuit zeros. At its worst, the zero drift in this range amounts to about 10 millimicroamps at the input.

The amplifier was, however, required for use with apparatus demanding a short-term stability of 1 μA . This was attained by mounting the transistors in holes drilled in a block of brass and subsequently wrapping the whole amplifier in several layers of foamed rubber. These measures ensure that the temperatures of the transistors are identical and that their temperature drift is very slow. If a correspondingly good long-term stability had been required, it could have been obtained by using a simple bimetallic thermostat to maintain the outer case of the amplifier at a substantially constant temperature. To eliminate initial drifts due to internal dissipation in the transistors, the amplifier is left in operation continuously. The total current consumption is less than 3 mA and a battery life of several months is obtained from three 3-cell torch batteries.

The amplifier gain has been measured over a useful range of ambient temperatures. It will be seen from Fig. 9 that a substantially uniform gain is maintained from 37°F (the lowest temperature at which tests were made) to 93°F. The upper limit is set by the bottoming of T_b .

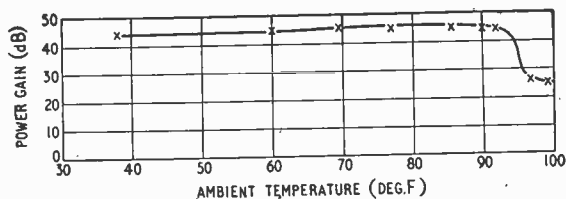

Fig. 8. Power gain variation with temperature in the circuit of Fig. 6.

Simple tests show no phase shift or irregularity in the frequency response of the amplifier below the limit imposed by the alpha cut-off frequency. The main limitation on the value of the amplifier arises from the low-frequency noise, corresponding to about 0.001 μA at the input.

Experimentally the Mullard Type OC71 transistors used for the first stage of the amplifier were replaced by Type OC70 transistors. The manufacturers' literature indicates that the noise level of the OC70 is some 6dB lower than that of the OC71. Consequently the unsteadiness of the zero might have been expected to be halved by using the low-noise type. In practice, however, no improvement could be discerned. The OC70 provides a slightly lower gain and it is more difficult to select matched pairs. Consequently Type OC71 transistors were retained throughout.

The transistors used in each stage were selected so that, as nearly as possible, those in each pair had identical values of α' and I_{co} . The pair having the lower value of I_{co} was, of course, used for the input stage. Although only a limited number of transistors were available at that time, it was found fairly easy to match values of α' to about 3% and I_{co} to about 10%.

REFERENCES

- ¹ T. E. Firlie and H. Winston, "Noise Measurements in Semiconductors at Very Low Frequencies." *J. Applied Physics*, Vol. 26, pp. 716-718, June 1955.
- ² H. C. Montgomery, "Transistor Noise in Circuit Applications." *Proc. I.R.E.*, Vol. 40, pp. 1461-1471, November 1952.
- ³ F. Oakes, "The Stability of Transistor Circuits." *Wireless World*, Vol. 61, pp. 164-167, April 1955.

Mobile Sound and TV Laboratory

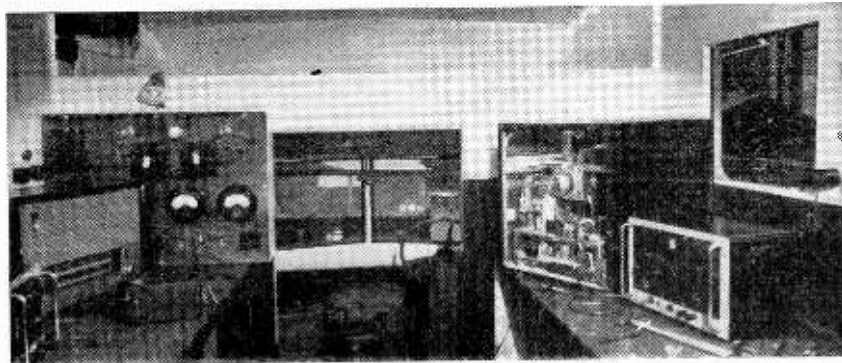

TO facilitate the testing of prototype sound and television receivers in different parts of the country Cossor's have brought into use a mobile radio laboratory. The vehicle, which is equipped with its own power supply, carries an extendible aerial system remotely controlled from the test bench. The equipment includes Model 1322 "Tele-check" and marker generator for Bands I and III, an f.m. receiver alignment generator and oscillographs.

AUTOMATIC WAVEMETER CALIBRATION

PHOTOGRAPHIC METHOD GIVING TABULAR NUMERICAL RESULTS

By D. P. THURNELL,* B.Sc. (Eng).

THE precision of wavemeter measurement cannot exceed the accuracy of the calibration, which is commonly recorded in a handbook or a calibration chart attached to the instrument. Re-calibration is necessary at intervals dependent on the use made of the wavemeter. Where the instrument is subjected to rigorous working conditions, as experienced with the Armed Services, the necessity of frequent re-calibration becomes onerous.

The Type BC221 heterodyne frequency meter, for instance, occupies a skilled technician for fifteen days, for it has 3,252 calibration points. The wavemeter in question is one used in large quantities and in order to speed up re-calibration an automatic apparatus† has been designed. The whole process of re-calibration from the generation of standard frequencies to the photographic recording of dial readings is entirely automatic and the apparatus can deal with five wavemeters per day.

A series of calibration frequencies (of the order of one part in 10^7 accuracy) are provided by a frequency standard. These are compared with the output frequency of the wavemeter under test. The wavemeter output frequency is continuously varied by a mechanical drive which simultaneously operates a mechanical counter. There is always a direct relationship between the counter and the position of the wavemeter tuning control.

The calibration frequencies and the continuously changing output frequency of the wavemeter are compared, using the heterodyne principle. After comparison an output is obtained which causes

pulses are applied as one input to a mixer circuit (4).

The output from the wavemeter (5) under test passes to an amplifier (6) and thence to the mixer (4). The wavemeter has its tuning dial firmly coupled to a mechanical drive consisting of an electric motor (7) and a precision gear box (8).

The output from the mixer circuit is amplified by a low-frequency amplifier (9), and applied as the input to a mono-stable trigger circuit (10).

One pulse output from the trigger circuit is fed via a commutator device (11) to effect the triggering of a thyatron circuit (12) which provides a firing pulse for the photographic flash tube (13) arranged evenly to illuminate a mechanical multi-digit counter (14). This is driven at a suitable speed to synchronize with the tuning control of the wavemeter and indicates the same figures as the wavemeter dial reading. Alternatively, it can be arranged to indicate the angular position of the wavemeter dial. When used with the BC221 heterodyne frequency meter the former arrangement is employed.

In correct alignment with the viewing aperture of the counter is a camera (15). At each flash of the tube (13) an image of the counter is recorded. The camera has a film wind-on control which is mechanically coupled to a solenoid-actuated mechanism (16).

* G. and E. Bradley, Ltd., Wembley.

Fig. 1. Block diagram showing main components and functions of the equipment.

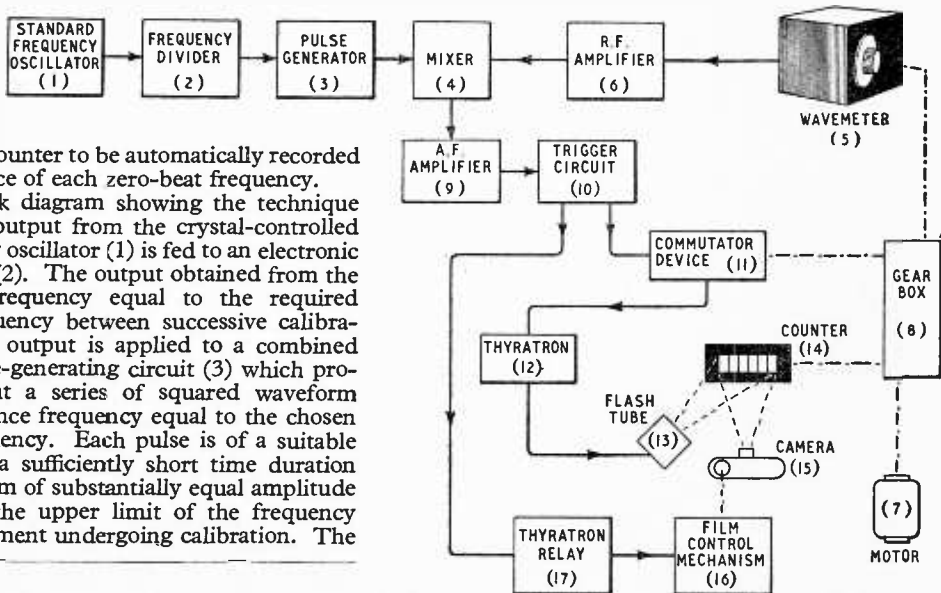

indications of the counter to be automatically recorded upon the occurrence of each zero-beat frequency.

Fig. 1 is a block diagram showing the technique employed. The output from the crystal-controlled standard frequency oscillator (1) is fed to an electronic frequency divider (2). The output obtained from the divider is at a frequency equal to the required increment of frequency between successive calibration points. This output is applied to a combined squaring and pulse-generating circuit (3) which provides at its output a series of squared waveform pulses at a recurrence frequency equal to the chosen increment of frequency. Each pulse is of a suitable amplitude and of a sufficiently short time duration to ensure a spectrum of substantially equal amplitude harmonics up to the upper limit of the frequency range of the instrument undergoing calibration. The

† Patent applied for.

The film control mechanism is supplied with energizing current pulses from a thyatron and relay circuit (17) whose control input is connected to an output from the trigger circuit (10) to ensure that the film is moved on for each exposure.

It will be assumed that the wavemeter has a frequency range of 100 to 200 kc/s, that its tuning control is capable of being read to one part in 10,000 of its complete range of movement, and that calibration is to be effected at every 2 kc/s over the wavemeter frequency range. In such circumstances the desired recurrence frequency for the pulse output from the circuit (3) is 2 kc/s and the standard frequency source (1) may operate at, say, 100 kc/s with the divider (2) effecting division by a ratio of 50:1. The motor (7) will be arranged to cause movement of the control of the wavemeter (5) over its complete range of movement while counter (14) is being moved from zero to a count state of 10,000.

The pulse input to the mixer (4) from circuit (3) comprises a series of equal-amplitude harmonics of the recurrence frequency (i.e., 2, 4, 6, 8 kc/s and so on upwards) to a frequency above the maximum operating frequency (200 kc/s) of the wavemeter. This implies a pulse width less than 1 μ sec. In consequence there will be produced at the output of the mixer circuit (4) a succession of zero beats, the first occurring when the wavemeter output is 100 kc/s, the second when the output is 102 kc/s, the third when the output is 104 kc/s and so on. The other harmonics of the 2-kc/s pulse repetition frequency are filtered from the mixer output in the amplifier (9) in which the bandwidth is arranged to be of very limited and low value, say 50 c/s in the present instance, so that a trigger input will be supplied by the amplifier to the trigger circuit (10) just before, but sufficiently close to, each occurrence of a zero beat output from the mixer. The small error so introduced (in this case about 0.05%) can be compensated for, if the wavemeter-dial rotation/frequency law is substantially linear, by offsetting the counter indication by a suitable amount from the dial indication. If this is not possible, increased accuracy can be obtained at the expense of speed by reducing the bandwidth of the amplifier (9).

When triggering of the circuit (10) occurs, an output of appropriate polarity is available to operate the commutator circuit (11). This commutator is necessary in order to delay the photographic exposure until the next occasion on which the

counter figures are all in line, since the least significant digit drum is continuously in motion. This is achieved by switching a bi-stable (flip-flop) circuit "on" with the pulse from the trigger circuit (10) and "off" with the next pulse derived from a photocell pick-up head energized by light interrupted by a slotted disc. This disc has ten slots and is fixed to the counter input shaft, the position of each slot corresponding to one of the ten positions in which all figures are in line. To avoid a blurred image a flash duration of approximately 100 μ sec is employed. When this occurs a photographic recording is made of the instantaneous indication of the counter.

The output pulse from the trigger circuit (10) terminates after a pre-determined time interval which is made long enough (with respect to the speed of movement of the wavemeter control) to prevent another triggering of the circuit (10) until the next zero beat is approached. Fig. 2 shows the amplitude/time output of the amplifier (9) during operation. The thyatron and relay circuit (17) operates after the exposure. By closing the associated relay contacts the solenoid-actuated mechanism (16) winds on the camera film to the next recording position in readiness for the next cycle of operation which occurs when the next zero beat is reached.

This procedure is repeated at wavemeter output frequency intervals equal to the recurrence frequency (i.e. 2 kc/s) of the pulses fed to the mixer over the whole of the frequency range for which calibration of the wavemeter is desired.

The characteristics of the optical system are so chosen that the developed film is produced at the correct size and pitch of figures and with a positive

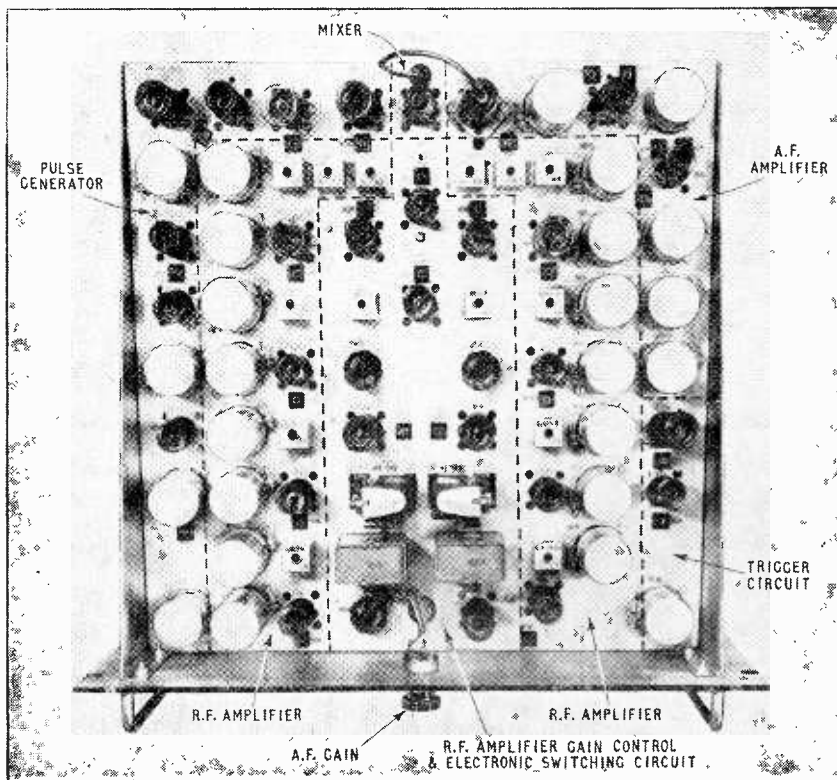

Plan view of chassis. The dotted lines indicate subdivisions of function.

Part of the automatic calibration equipment showing mechanical drive for wavemeter tuning control.

image (black on white) so that it may be cut and mounted directly into a calibration booklet for the particular instrument, in which columns of the appropriate frequencies have already been printed.

The range of instruments which may be calibrated by the apparatus described can be extended by the employment of ancillary equipment, such as a frequency divider interposed between the wavemeter and the r.f. amplifier, when the wavemeter is one operating at very high frequencies. It may also be more convenient to use a servo-mechanism for the drive system between the motor (7) and the elements (5), (11) and (14).

Operation of the apparatus over other frequency ranges can best be described by examples. For instance, calibration has been effected at 10-kc/s intervals from 20 to 40 Mc/s. This required the

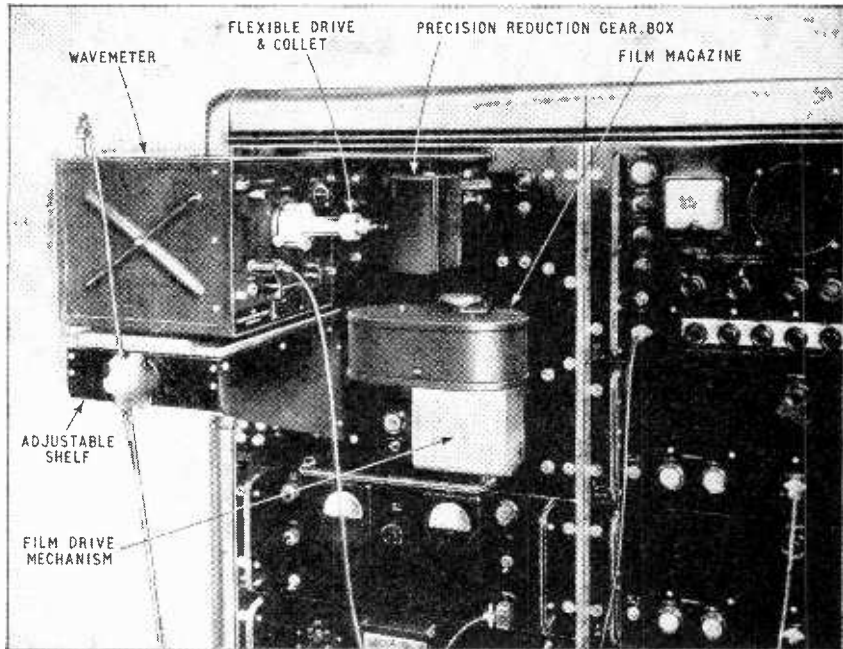

generation of a pulse of duration less than $10\mu\text{sec}$ with a time jitter less than $1\mu\text{sec}$.

In general, almost any frequency-calibration problem can be tackled by similar equipment. An important application is the automatic calibration of radio receivers where a high order of accuracy and a large number of calibration points are involved. The calibration record may then be in the form of a flexible scale (e.g., 35-mm film), coupled to the tuning mechanism, on which are recorded the frequencies to which the receiver may be tuned.

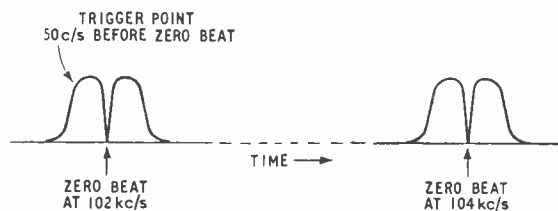

Fig. 2. Output amplitude/time characteristic of amplifier (9) during operation.

Further Developments

In order to eliminate the complication involved in photographic processing, a printing counter is under development. This is designed to replace the optical system and is provided with a mechanical storage device which enables a print to be made without interrupting the continuous drive to the input shaft.

The advantages of the system described may be summed up as follows:

- (1) The elimination of human error during calibration;
- (2) The elimination of human error in copying figures or in interpolation;
- (3) The reduction of electrical error due to long-term temperature changes, thus disposing of the necessity for using a temperature-controlled calibration room;
- (4) The increased speed of output and consequent reduction of staff.

As in other fields to which automation can be introduced, these advantages are economically realized where adequate numbers of similar instruments are to be dealt with and where the requirements of accuracy and multiplicity of calibration points are such as to justify the design of suitable equipment. Where large numbers of instruments are involved, a considerable economic advantage may be gained over hand-calibration methods.

Specimen of calibration table as it appears after the film record has been registered with the printed frequency table.

LETTERS TO THE EDITOR

The Editor does not necessarily endorse the opinions expressed by his correspondents

Television Systems

IN your July issue you again return to the question of choice between a 625-line television system and a 405-line system for colour TV. Although I put my arguments at some length in my previous letter, there is one point in your Editorial to which I must reply.

You assert that any country sufficiently developed industrially to have any kind of TV service would probably make its own receivers. This is indeed a most defeatist attitude to adopt in view of the vital importance of our own export market. It will be many years before some of the underdeveloped countries can possibly start making television receivers, especially those for colour reception, though popular demand may well bring a television service to them. Are we then to sit back and see our competitors reap a rich harvest by exporting to these countries while we must wait to see whether or not factories are erected to make receivers on the spot? You may be sure that the introduction of television in a country will not await the indigenous production of receivers.

I am told that in Iraq, for instance, about 100 people watch each set whenever programmes are transmitted. This is surely a fair indication of the popularity of television and of future demand for imported sets. A radio set is much easier to make than a television set, yet in 1955 Germany sold some twelve million pounds worth of radio sets overseas while Britain also sold about three and a half million pounds worth in the same period. Surely, if it is possible to export these large quantities of radio sets, then there can be no possible justification for assuming that television sets will not be a profitable export.

As I said before, a healthy export market must be based on home demand. Colour television is certainly on its way and the great potential markets which will arise in these, at present, underdeveloped countries will undoubtedly be for sets operating on the 625-line system. All the more reason why we in this country should not only fall into line but lead our competitors in this field.

London, W.1. ROBERT RENWICK.

WITH reference to your article "Television Picture Quality" in your August issue, reprinted from *Wireless Engineer*, May I ask why W. T. C., in studying the vertical definition does not mention the 0.7 coefficient, which is normally accepted, due to the fact that not all the active lines are capable of representing separate resolution lines?

Madrid. MARIANO MATAIX.

Comment :

THE coefficient of 0.7 does not in any way affect comparisons of the vertical definitions obtainable with different television systems because it affects them all equally. It does, however, affect a comparison of vertical and horizontal definition, in that when it is included the nominal figure for the relative definition in the two directions is altered.

The mechanisms limiting definition in the two directions are quite different both physically and in their visual effect. Any method of comparison is thus largely arbitrary. If I had said that the vertical definition is to be considered as equal to 0.7 of the number of active lines some of my statements about the relative definitions in the two directions across the picture would have been modified, but the comparisons of one system with another would have been unaffected.

The experimental fact that a 405-line picture with unrestricted bandwidth is more pleasing than a 625-line picture with 5Mc/s bandwidth is not affected by whether

one says that the normal 405-line system has roughly equal horizontal and vertical definition, as I did, or whether one says that it has lower vertical than horizontal definition, as I should have done had I introduced the 0.7 coefficient.

W. T. C.

I HAVE been much interested in the controversy on colour standards for television. The need for some standards to be laid down if we are to make any practical advance towards obtaining a colour service is obvious, and I should have thought that the unknowns are at present too numerous for any reasonable estimate of the economics of receiver production, let alone the manufacture of equipment for programme transmission.

It would be interesting to know what the official Post Office attitude is towards colour. The main trunk lines for both B.B.C. and I.T.A. networks are limited by design to a 3-Mc/s bandwidth, and to convert them to a wider bandwidth would take time and is probably out of the question while the I.T.A. is still expanding. Similar considerations apply to the local and temporary circuits, due to the P.O. amplifier design. Colour in less than five years would therefore seem to be geared to a 3-Mc/s bandwidth and existing communications.

I think it important not to overlook the communication aspect of this problem. Programme operation entails remote control of the transmitter, and transmitter and receiver design are therefore only part of the problem.

Among other parameters which have been little mentioned but whose standardization is probably essential before a colour service can be considered seriously are the transfer characteristic of the receiving tube, and the stray light factor at the receiver. In the U.S.A. this transfer exponent is standardized at 2.2. Is this a correct standard? Again, would 3 per cent of maximum luminance be regarded as a reasonable stray light factor? Unless they are given these two parameters, it is difficult to see on what basis the designers of commercial camera chain equipment for colour would work.

Woking. R. F. COLVILE.

Noise in Carbon Resistors

I AM indebted to Dr. D. A. Bell for his comments on my article on "Characteristics of Fixed Resistors". Regarding the point of current noise, I have endeavoured to be cautious when making statements concerning resistors generally, as I would not like to state that all resistors have the same characteristics with regard to noise until all types of resistor have been measured. Chipman, in addition to Hollins and Templeton, has shown the low-frequency power spectrum to be true for certain types of resistor, and as more data is obtained on, for instance, metal film and oxide film resistors the figure "below about 10 c/s" should certainly be changed to "below about 1 c/s".

The reference to $\log f_2/f_1$ is correct, and if my book is referred to (on page 49) it will be seen to be correct there; the omission occurred in the process of transcription from the book.

Whilst the figures given in Table 3 are acceptance limits they are, in fact, based on the results of a large number of measurements and they do represent what is implied—the maximum noise one would normally expect on typical resistors. The formula $0.5\mu V/V$ is still used in RCS 112 for cracked carbon resistors but I would agree that this does not purport to reflect the true noise level. In the absence of precise data it serves as a good guide to the design engineer and it is clear from Table 3 that if an engineer assumes the limit given in RCS 112 then he will find that he will not go very far wrong.

The + and - signs in Fig. 6 should be omitted. With regard to the rule that film-type resistors should be used, this is generally correct. Fig. 8 was made up as a composite graph, based on the results of measurements on carbon composition, carbon composition film and cracked carbon film resistors. In all cases the r.f. performance of the film resistors was superior to that of the composition resistors.

If I may be allowed to comment on the last paragraph addressed to "Cathode Ray", it is useful to check by c.r.t. methods composition resistors used as noise standards with no current flowing, as sometimes additional noise may be superimposed from sources such as poor terminal contacts on slightly faulty resistors.

I would like to thank Dr. Bell for his valuable service in, as he says, "dotting i's and crossing t's" and I hope the above comments will also be found useful.

Great Malvern.

G. W. A. DUMMER.

Fringe Area Reception

ON Sept. 16 an unsuccessful attempt was made to receive the Crystal Palace TV signals in America. At the same time many thousand attempts to receive the same signal were being made in East Anglia and surrounding counties which were also unsuccessful. After six years of promises, it is disheartening to those who purchased receivers for some reception from Alexandra Palace to now have their receivers rendered nearly useless because of fading down to 10 μ V/metre nearly every day. The south coast has received a better service at the expense of the northern limits of the area.

The B.B.C. charter makes some mention of bringing its services to the widest audience and the B.B.C. claims (I think) 98 per cent of the population served, which means one million without a TV service. Whilst not wishing to belittle the Corporation's magnificent efforts, a million is a lot of people and I suspect that signals of 100 μ V/metre are included in the service area. If so the B.B.C. is satisfied with very low picture standards and there must be few areas that average 100 μ V/metre without severe fading. In some areas of Huntingdon county a three element array at 50ft will hardly guarantee one evening per week without loss of picture. Ponder on this those who have forgotten where the contrast control is situated.

A wide strip of land extending to the Wash has no satisfactory sound or television service of any kind, yet the full licence fee is demanded by law from those who

valiantly try to obtain some entertainment. If fees were payable according to the service, would these forgotten (except on January first) areas be included in future plans?

St. Ives, Huntingdon.

H. S. KING.

IN some fringe areas, car ignition noise is beyond description in intensity.

On vision, it is comparatively easy, by attention to line sync-circuits and use of a simple diode limiter to eliminate 99 per cent of the effects, but on sound it is a different story. No amount of "limiting" seems to have much effect—I, personally, have installed three limiters, all at once!—yet experience shows that with f.m. noise reduction is fairly easy.

One is led to believe that the reason the U.S.A. is fairly free of complaints about ignition noise is due to the use of flywheel syne and f.m. sound, therefore I would like, on behalf of long-suffering fringe viewers in the south, to stake out a claim for, specifically, an f.m. sound carrier between Channels 1 and 2.

Peacehaven.

R. G. YOUNG.

Underwater Television

"DIALLIST'S" reference to underwater television (September issue) cannot pass without comment. Several instances where the medium was used occurred before 1951. Perhaps the first use was made in Germany prior to the last World War; certainly in 1947 it was used in connection with the atomic bomb explosion at Bikini Atoll. In 1948 the Scottish Marine Biological Association began preliminary work using an underwater camera for the study of marine life. Actually in 1949 a demonstration was given at the London Zoo using an E.M.I. C.P.S. Emitron camera.

The operation to locate the ill-fated *Affray* in 1951 was probably the next important use and also the first use as an aid to marine salvage. The Admiralty Research Laboratories at Teddington made the chamber to house the camera, which was a normal Marconi broadcast type about to be supplied to the B.B.C.

The first television camera to be designed purely for submarine use was the work of Pye, Ltd. The design was in an advanced stage just prior to the operation to locate the "Comet" off Elba. A suitable casing was designed for work down to 1,200 feet and the camera was subsequently used in this operation with great success.

Southampton.

B. A. HORLOCK.

SHORT-WAVE CONDITIONS Prediction for November

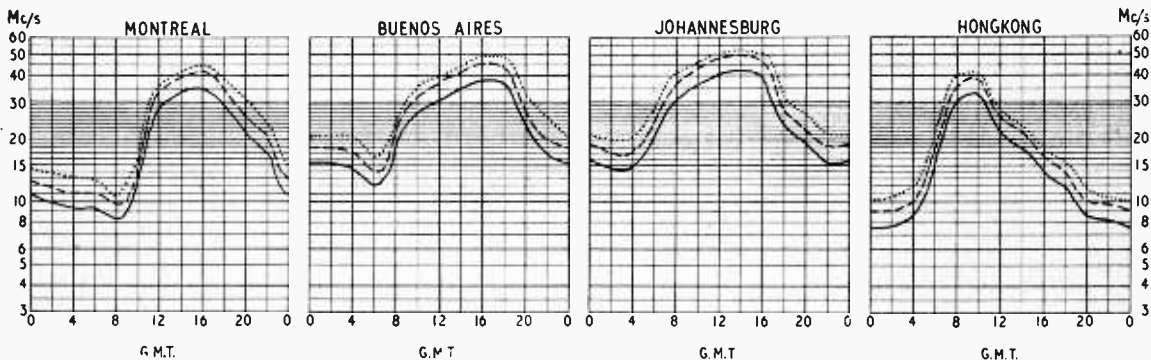

THE full curves given here indicate the highest frequencies likely to be usable at any time of the day or night for reliable communications over four long-distance paths from this country during November.

Broken-line curves give the highest frequencies that will sustain a partial service throughout the same period.

..... FREQUENCY BELOW WHICH COMMUNICATION SHOULD BE POSSIBLE FOR 25% OF THE TOTAL TIME

--- PREDICTED AVERAGE MAXIMUM USABLE FREQUENCY

— FREQUENCY BELOW WHICH COMMUNICATION SHOULD BE POSSIBLE ON ALL UNDISTURBED DAYS

Pocket Transistor Receiver

Long-wave Regenerative Circuit with Novel Stabilizing System

By P. THARMA,* B.Sc (Eng.)

THE receiver described in this article is the result of an investigation to determine the smallest and the most economical design for a personal set. As the receiver was to be self-contained it was necessary to use a small ferrite rod aerial and this type of aerial, in turn, demanded a highly sensitive circuit. High sensitivity can be obtained either with a super heterodyne circuit, which requires about four transistors, or by using regenerative detection, when only two transistors are required. By suitable circuit design the regeneration can be made reasonably stable and gives good results.

The use of the OC71 transistor limits the frequency of reception to below about 400kc/s. Hence the design of the receiver has been confined to reception of the Light Programme transmission on 200kc/s.

The useful range of this receiver with the ferrite rod aerial is about 120 miles from Droitwich, depending somewhat on local conditions. Adjustments become unduly critical for greater distances. The receiver is directional, having a figure-of-eight pick-up characteristic. An external capacitive aerial can be used where practicable and gives much greater sensitivity. Owing to variations of transistor characteristics with temperature, occasional readjustment of the controls will be necessary.

The receiver, which operates into a hearing-aid type earpiece, can be made not much bigger than a packet of 20 cigarettes.

A complete circuit diagram is given in Fig. 1. The first transistor functions as the regenerative detector, with signal input to the emitter, regeneration being provided by means of the feedback coil L_2 . D.C. bias to the base is provided by means of the potential divider R_1 and R_2 . Resistors R_1 , R_2 , R_3 and R_8 provide stabilization of the collector current, which is $100\mu\text{A}$. Capacitor C_7 decouples the base for r.f. and a.f. Capacitor C_5 decouples R_1 for r.f. only and provides stabilization of regeneration, as explained later. Capacitor C_6 decouples R_2 for r.f. and a.f. The a.f. circuit design is conventional except for a small amount of positive current feedback which gives an increase of gain.

A Ferroxcube rod is used for the aerial. Grade A4 of this material has the highest useful permeability at 200kc/s and is

*Mullard Ltd.

therefore specified. A fairly short rod has been used in this design to give ready portability. Much greater pick-up can, however, be obtained with a longer rod. An external capacitive aerial can be used by coupling directly to the tuned circuit via a 22-pF capacitor. An earth should then also be connected.

A regenerative detector performs two functions: (a) detection, and (b) providing r.f. feedback to reduce the damping of the input circuit. Detection takes place in a transistor circuit at low currents due to non-linearity of the input characteristic and is most efficient at very low currents. However, the r.f. gain decreases with decreasing current. This decrease is gradual to $75\mu\text{A}$ and rapid for lower currents. Satisfactory operation was obtained at a collector current of $100\mu\text{A}$ using the transistor in the earthed-base mode.

Positive feedback to produce regeneration can be introduced in several ways. The sensitivity of the circuit increases as the feedback is increased towards the point of oscillation and the maximum usable sensitivity depends largely on the smoothness of controls and the stability of the circuit. Smooth regeneration control and adequate stability have been attained by careful coil design and the use of a stabilizing circuit, which may be of interest also in other applications.

In this circuit (see Fig. 1) the capacitor C_5 is chosen so that only the r.f. is bypassed. This provides stabilization of regeneration.

Suppose that the input characteristic of the transistor is similar to that shown in Fig. 2(a). This type of demodulator characteristic gives the same detection efficiency for all signal levels and the r.f. gain is constant provided the working point is at 0.

Fig. 1. Complete circuit diagram of the receiver.

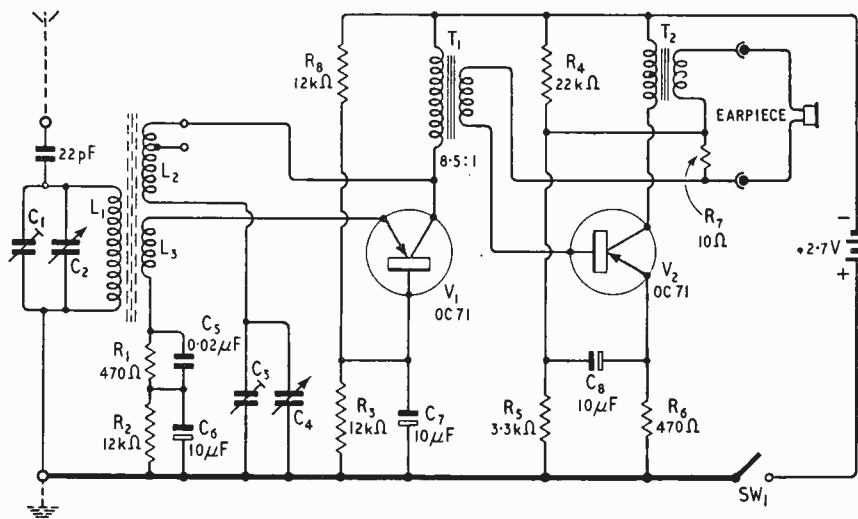

The actual input characteristic of the transistor is approximately exponential, as shown in Fig. 2(b). This type of characteristic gives at all working points detection efficiencies and r.f. gains dependent on the signal amplitude.

Variation of detection efficiency results in a.f. distortion and is undesirable. A more important consequence when regeneration is used is the variation of r.f. gain with signal. If the circuit is adjusted near the point of oscillation for low signals, it will burst into oscillation for higher signals (due to rise in signal level or on peaks of modulation).

A resistance in series with the emitter makes the characteristic of Fig. 2(b) approach that of (a) but also reduces r.f. gain as well as detection efficiency. A large amount of regeneration is therefore required to get any sensitivity. This is both undesirable and difficult to obtain.

A resistance shunted by a capacitance (R_1 , C_5 in Fig. 1) where the capacitance is large enough to bypass only the r.f. frequencies, has a much smaller effect on the r.f. gain, thus making efficient regeneration possible. The a.f. voltage across R_1 moves the operating point in phase opposition to the a.f. output provided by the demodulation process. This negative feedback greatly reduces the non-linearity of the latter process, and by so doing also reduces the variation in r.f. gain, which variation is proportional to the non-linearity of demodulation. This makes the characteristic of Fig. 2(b) approach that of (a) as far as dynamic operation is concerned. The system also tends to counteract variations in those characteristics of the transistor affecting gain. These advantages normally outweigh the loss in a.f. gain. However, occasional readjustment of controls may be necessary due to the influence of temperature.

The coils are wound on the Ferroxcube rod as shown in Fig. 3. This design takes into account Q factor, coupling coefficients, optimum wire size and variation of transistor characteristics. One or other of the tappings gives better results and this can be determined by experiment.

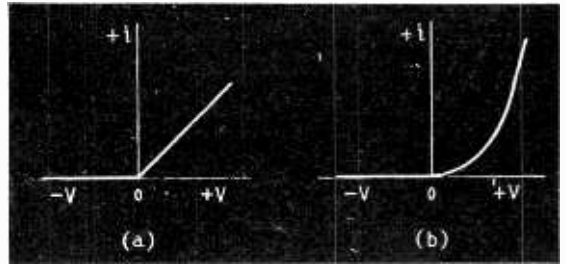

Fig. 2. Transistor demodulation characteristics: (a) an ideal curve giving linear demodulation; (b) the actual characteristic with demodulation and gain non-linear.

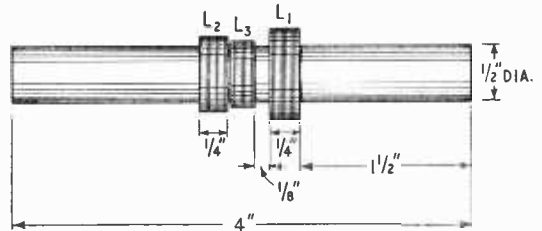

Fig. 3. Details of the coils wound on the Ferroxcube rod aerial.

COIL WINDING DATA

All three coils are wound with 35 s.w.g. enamelled double-silk-covered wire on a core consisting of a Ferroxcube rod 4in long and $\frac{1}{2}$ in in diameter (Grade A4, FX1091).

L_1 = 100 turns wound multilayer over $\frac{1}{4}$ in.

L_2 = 57 turns with tap at 40 turns, wound multilayer over $\frac{1}{4}$ in.

L_3 = 17 turns, single layer, close wound.

The coils are all wound in the same direction and are insulated from the core with Sellotape. Tuning coil characteristics: $Q = 150$, $C = 425$ pF at 200kc/s, unloaded.

LIST OF COMPONENTS

Resistors (all 1/20W, although larger types could, of course, be used)

- $R_1 = 470\Omega$, 10% tolerance
- $R_2 = 12k\Omega$, 10% "
- $R_3 = 12k\Omega$, 10% "
- $R_4 = 22k\Omega$, 5% "
- $R_5 = 3.3k\Omega$, 5% "
- $R_6 = 470\Omega$, 5% "
- $R_7 = 10\Omega$, 5% "
- (see text)
- $R_8 = 12k\Omega$, 10% "

Capacitors

C_1 and C_8 = Compression trimmer, max. capacitance 400pF, or suitable fixed values.

C_2 and C_4 = Ceramic trimmer, sweep 5-40pF, TCC type TCK0540, or 8-50pF (Eric Resistor No. 557/8-50pF) with drive for external adjustment.

Capacitors (continued)

$C_5 = 0.02\mu F$ paper, 150V working.

$C_6, C_7, C_8 = 10\mu F$, 3V working, electrolytic, TCC type No. CE68AA/W or equivalent.

Lower values of C_6, C_7 and C_8 (down to $2\mu F$) can be used without noticeable effect on the audio response.

Transformers

T_1 = Ratio 8.5:1, Fortiphone type N23 or equivalent.

T_2 = Ratio 4.5:1, Fortiphone type N22 or equivalent.

Transistors

$V1$ = Mullard OC71.

$V2$ = Mullard OC71.

Earpiece

Fortiphone type "L," 250- Ω impedance or equivalent.

Cord

Hearing-aid type, 4ft length, to suit earpiece and socket.

Socket

For cord plug.

Battery

TR152 Mallory.

Switch

Miniature slider switch, Fortiphone type SW/5.

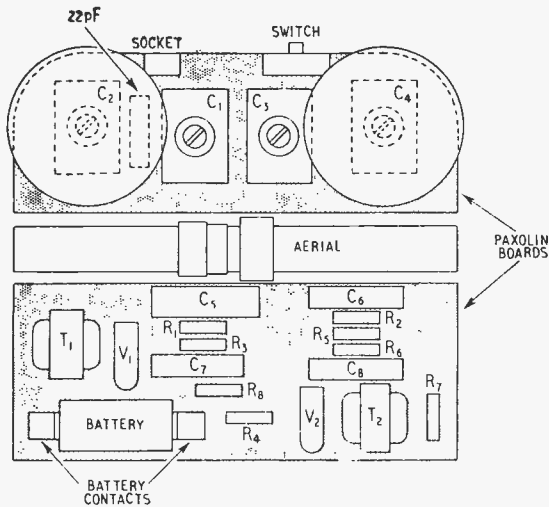

Fig. 4. Constructional details of the receiver.

The following considerations guided the design. A value of 6 : 1 for the ratio of the number of turns in the tuning coil to the number of turns in the emitter coil gave optimum matching between the tuned circuit and emitter input. The reaction winding has to be tightly coupled to the emitter coil. Too large a number of turns on the reaction winding necessitates a small capacitance for C_3 and makes the reaction control coarse and difficult to adjust and introduces a backlash effect on it. If the number of turns on the reaction winding is small it may not be possible to obtain regeneration close to the point of oscillation. From this it appears that the reaction winding has an optimum value for each transistor. Best results are obtained when the winding is such that the capacitance of C_3 is about 300–400 pF when adjusted for maximum sensitivity.

Transformer coupling is used between the detector and output stage. As the output impedance of the detector transistor is high, due to operation at low current, a ratio of 8.5 : 1 is used for the coupling transformer. The primary inductance must be high enough to give an adequate frequency response (38H gives a drop of 3dB at 300 c/s).

An output transformer is used to match into the earpiece, which has an impedance of 250 ohms at 1,000 c/s. The choice of the output transformer ratio is a compromise between gain and output power. A transformer ratio of 4.5 : 1 with a battery supply of 2.7V gives good results, providing sufficient power for comfortable listening.

Positive current feedback is applied to the output stage via the resistor R_7 . If this is selected to give an increase of gain of about 10dB, there is no serious effect on quality and the stability margin is adequate. The value of R_7 required depends on the transistor V_2 and is of the order of 10Ω. This positive feedback may be omitted if the receiver is intended for use in high field-strength areas. D.C. stabilization of the operating point of the output transistor is provided by means of the resistors R_4 , R_5 and R_6 .

In certain applications it may be preferable to feed the a.f. signal into an existing high-gain amplifier system, such as a hearing aid. Under these circumstances the output stage may be omitted and the a.f. signal taken directly from the detector stage. If a low impedance output (1,000Ω) is required, this

could be taken from the secondary of the transformer T_1 . A high-impedance output can be taken from the junction of the transformer T_1 and collector of V_1 via a r.f. choke.

Regarding the battery, mercury type dry cells are best suited for use with this receiver. The good voltage stability of these cells allows the transistor to operate under optimum conditions during the whole battery life. The total drain is about 1mA and cells such as the Mallory type TR152 would give about 350 hours life at a cost of less than 1/6th penny per hour.

Fig. 4 shows a possible layout of the components. The layout is not critical, except that the transformers T_1 and T_2 should be spaced far apart to prevent interaction. Trimmers C_1 and C_3 are preset, whilst trimmers C_2 and C_4 are adjusted in use. Small variable capacitors of the required sweep are not easy to obtain. Compression trimmers have been modified by replacing the existing trimming screw with a larger screw to which a knurled disc is attached. These are mounted so that the edges of the discs project through slots in the case.

For the setting-up procedure, the lower of the two tapings of the reaction winding should be tried first. The variable capacitors C_2 and C_4 are set in mid-position. The reaction capacitor C_3 is set at maximum and the receiver switched on. If the circuit is in oscillation a whistle will be heard as the capacitor C_1 is varied, when the frequency of oscillation approaches the signal frequency. The reaction capacitor C_3 is then gradually reduced and by alternate adjustment of C_1 and C_3 the signal can be tuned in. (If the circuit does not oscillate the higher tapping of the reaction winding should be tried.) The external aerial and earth are then disconnected. Some retuning and adjustment of the reaction control is then necessary to obtain optimum reception with the Ferroxcube rod aerial alone.

The author is indebted to L. H. Light for valuable advice in the design of the circuit.

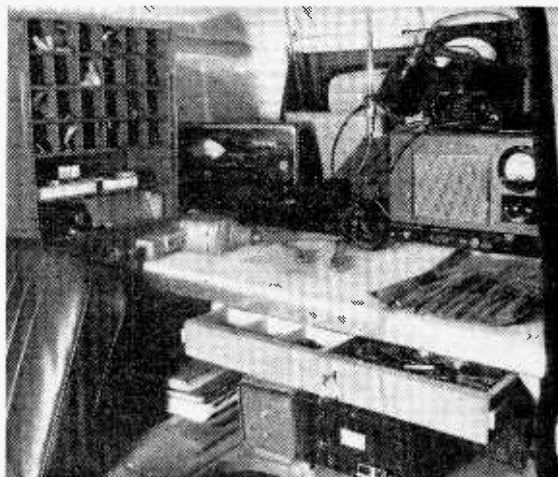

ON-THE-SPOT fitting of car radio within the Greater London area is now provided by Rootes Ltd., who have equipped a van specially for the task. It is a combined installation-demonstration vehicle and is itself fitted with the new 20X Radiomobile receiver. Being on call (Ladbroke 3232) it obviates motor traders carrying stocks of radio parts.

The author's living room (reverberation time 0.46 sec) showing placing of the loudspeakers for stereophonic sound reproduction.

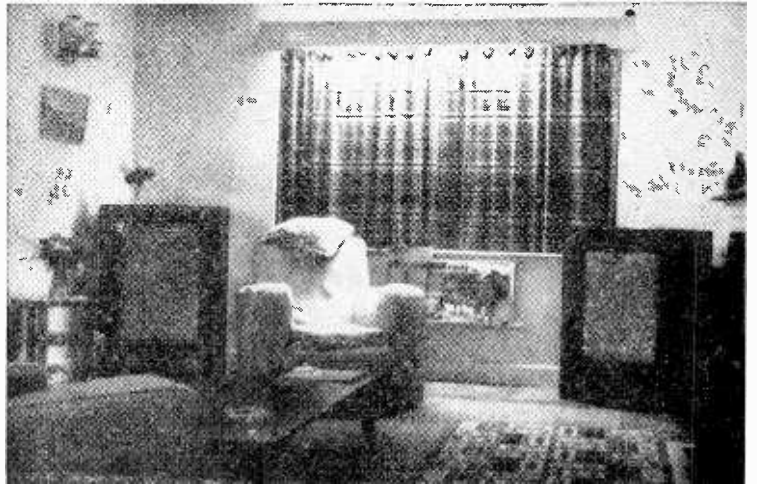

AN APPRECIATION AND SOME EXPERIMENTS IN PSYCHO-ACOUSTICS

By J. MOIR,* M.I.E.E.

Stereophony in the Home

IN every key cinema in the country a stereophonic sound film system is now installed, and as the sound quality that can be obtained from a proper stereophonic recording is so impressive it is natural to apply similar techniques to domestic sound reproducer systems. The recently released musical film "Oklahoma" is an excellent example of the results that can be obtained in the cinema from a stereophonic recording of music and singing.

The advantages of stereophonic sound reproduction are at least as great in the home as in a large hall, and the following notes are based on experience gained in running a two-channel stereo system in ordinary domestic surroundings. The views may be a little coloured by a professional interest in the design of stereo sound systems for cinemas.

It is not proposed to recapitulate the fundamentals of stereophonic sound reproduction, for this aspect has been adequately dealt with in previous contributions to *Wireless World*† but it will be remembered that two, three or five separate channels must exist between the recording studio and the reproducing room, the stereo performance improving as the number of channels is increased. Practical considerations restrict the number of channels to two when domestic equipment is considered.

Stereophonic recordings were made many years ago by Blumlein of E.M.I. using simultaneous lateral and vertical modulation of a single groove on a gramophone record, but magnetic tape has so many advantages over discs that all current British releases are on twin-track magnetic tape. It seems likely that tape will become the standard storage medium though some of the smaller American companies issue a few discs having two recorded grooves.

In England the recordings available so far have been released on $\frac{1}{4}$ in magnetic tape by the E.M.I.

* Electronics Engineering Dept., British Thomson-Houston Company.

† "Stereophonic Sound," J. Moir, March, 1951. "Two-Channel Stereophonic Systems," F. H. Brittain and D. M. Leakey, May & July, 1956.

group under the "H.M.V." and "Columbia" labels and these are the only ones of which experience has been obtained. Without waiting for the end of the story it can be said at once that stereophonic reproduction in the home is a thrilling experience and one that results in a strong desire to "ask for more".

First a few words about the recorded tapes. The standard $\frac{1}{4}$ in tape provides space for only two tracks and a 30-mil space (approximately) between them to minimize crosstalk. The dimensions are as in Fig. 1.

A stereophonic recording demands that the two recording heads be in an agreed position and that the replay heads be in the same relative position. This is essential if the recording system is to preserve the time differences that are so important to a good stereo performance. E.M.I. arrange their recording heads in line across the tape and it is thus essential that the replay equipment should also use heads with their replay gaps in line.

The microphone technique now employed in the E.M.I. is based on the Blumlein proposals, two directional microphones being mounted one above the other and mutually at right angles. However, our present purpose is to discuss the results obtained under domestic conditions rather than the studio techniques.

Equipment Used

Commercial equipment for playing "Stereosonic" tapes is available from several advertisers in *Wireless World*, but the price of a complete replay chain is a little on the high side for anybody on an engineer's salary; in consequence the writer's equipment shows signs of cinematic connections! For the enthusiast willing to assemble his own equipment several firms have available tape decks, including two compensated pre-amplifiers with an output in the region of one volt across 500 ohms. At a still lower price a tape deck can be obtained and the pre-amplifiers and main amplifiers assembled at home.

The tape reproducer used in my experiments is a

Ferroglyph 2C/NF having in-line heads and an output of about one volt from the two internal preamps. The main amplifiers are some standard units used in the smaller cinemas and having frequency characteristics within 1dB of each other over the whole audio-frequency range. Several types of loudspeakers have been tried, but it is still unfortunately true that the most expensive loudspeakers give the best reproduction. These particular examples are dual-channel, horn-through-the-centre-pole type (B.T.H. Type K10A) mounted in ported cabinets. They can be seen in the accompanying photograph of the living room. If the room is large enough high-quality speakers of this type are ideal, but they are not essential, a point that will be referred to later. The seating, a settee and two easy chairs, was arranged across the room about 10-12 feet away from the speakers.

With this arrangement the results obtained are outstandingly good and represent a much greater improvement over long-playing records than the l.p. records show over the old 78-r.p.m. recordings. The ordinary technical criteria, low harmonic distortion, wide frequency range, greater volume range, and low background noise, are inherently satisfied in a good magnetic tape recording and all the tapes tested set a standard much higher in these respects than any but laboratory examples of disc recording.

Surprisingly enough these characteristics received little comment from the 20-30 friends who have heard the results. What did receive comment from everybody, whether technically or non-technically minded, is the extraordinary improvement in clarity, the complete separation of orchestra and singers, the apparent size of the orchestra and the ease with which one can listen. This last point is a rather unsuspected and rather under-emphasized advantage of stereo recordings. One listening session ran into a couple of hours without the slightest sign of fatigue though the playing of a good l.p. record immediately brought the comment of "How hard that is to listen to after hearing the tapes".

Loudness Levels

The work of Somerville and Brownlees in England, and Chinn and Eisenberg in America has shown that the public have a marked preference for lower-than-original sound loudness levels when reproducing music at home. This has been confirmed on many occasions in the present house, peak levels greater than about 85 phon always raising adverse comment from the other members of the family. After ten minutes playing of the first stereo tape it became obvious that peak loudness levels well above 85 phon were being experienced, so the sound level meter was brought out. This confirmed that the peak levels were in the region of 95-98 phon, a loudness level that would certainly arouse protests if the standard monaural system was being played. Even when disaster was courted by a direct question "What about the loudness?" only one listener in the group of six thought that "it was a bit loud".

A few words about some of the tapes that have been played "The Marriage of Figaro" by the Glyndebourne Opera Company (HMV SAT 1007) is an outstanding example of the advantages of a stereophonic recording. Normally I have no special liking for opera sung in Italian, but this tape was played at least ten times during one day for the sheer pleasure

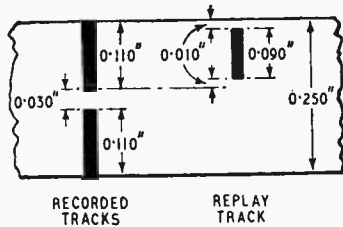

Fig. 1. Track dimensions of E.M.I. "Stereo-sonic" records.

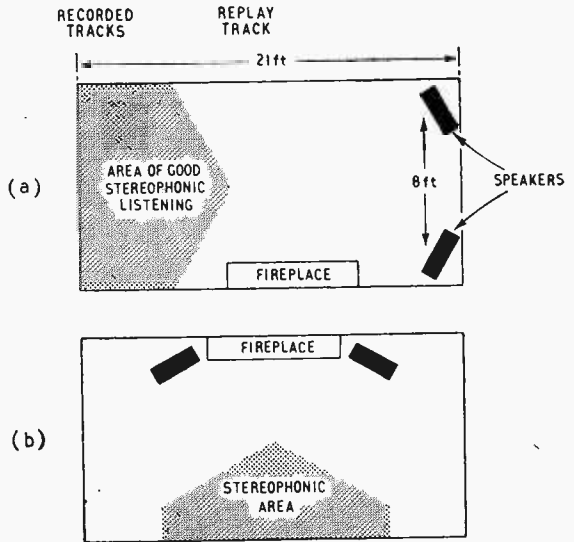

Fig. 2. Alternative positions tried for the loudspeakers in a living room.

of hearing the performance with all the spatial characteristics of the original. The orchestra is a separate group spaced from the singers, and the principal singers appear against the choral background without the least confusion. This is a recording to demonstrate to friends who believe they have a high-quality disc recording system!

Orchestral music is almost equally impressive, the Classical Symphony (Prokofiev, No. 1 in D Major) SDT 1750, being most satisfying both technically and musically. This was another recording that was replayed at least ten times during one week-end, always bringing all domestic activity to a standstill. A long experience of high fidelity at home suggests that continued satisfaction is a rarity if records are being played.

It must not be thought that a stereo system is only suitable for "serious" music; Phil Green and his orchestra in "Interlude for Melody," Columbia BTD 701, is another outstanding example of the advantages of stereo recording, though my eleven-year-old daughter informs me that Phil Green and his band are a "square". I am not sure what this means, but I suspect that he plays *music* rather than merely making a row. Perhaps somebody more attuned to the younger mind or having access to a suitable dictionary can translate the expression into English. A fair number of other recordings have been played, all with real delight, but those quoted might make a good foundation for a tape library.

Some twenty people have listened to the equipment at various times, most of them being high-quality enthusiasts though diluted by a wifely accompaniment. Without exception all their comment has been extremely favourable, but perhaps the greatest compliment is that three ladies sat for more than an

hour listening to opera in Italian and music by Prokofiev and Sibelius without saying a single word to each other except in the intervals. In a very long experience of domestic high quality I have never known this happen when playing records. The explanation is probably fairly simple; the reproduction is so realistic that it would just be sheer bad manners to indulge in conversation.

Some of the more technical conclusions reached as a result of experiments are probably of interest. The loudspeakers used each have a fairly uniform polar distribution over an angle of about 60 degrees. Speakers having a less uniform angular distribution need to be placed more carefully but give very good results if this care is taken. The two ported cabinets were placed in the corners of the room, pointing down the length of the room and turned outwards to make an angle of about 30 degrees with the wall behind. The cone centres were then about 8ft apart and the best listening position about 10-12ft away. At greater distances the stereo effects existed over the whole floor area out to the end of the room 21ft away. Listening positions closer to the loudspeakers than the speaker spacing lose a good deal of the stereo impression.

Several types of speaker have been tried and in general the better the individual speakers, the better the stereo result. However, the quality of the speaker and particularly the frequency range covered appear much less significant when using a stereo system. Any enthusiasts thinking of trying domestic stereophony need not be deterred by the absence of two speakers of top-class quality. When listening to a real orchestra the quality is not judged by the frequency range of the instruments, and the same attitude develops when using a stereo reproducing system. The frequency range that is reproduced seems much less important than the sense of size and spatial distribution produced by the system.

Loudspeaker Positions

Speaker positioning is a bit of a problem if the best listening position is to be integrated with normal domestic activity and the viewing of television. Speakers placed across the end of the room as in Fig 2 (a) give very satisfactory results, but are generally difficult from other points of view. A speaker placed at each side of the fireplace as in Fig. 2 (b) has advantages, in that it faces listeners seated round the hearth but the heating system needs to be a little better than "standard British" in order that the audience should be comfortable eight or ten feet from the fire. Seating positions outside the area demarcated by the speaker positions are not very satisfactory. The room used for the majority of the tests is fairly good acoustically (measured reverberation time 0.46 seconds at 500 c/s) but the acoustics of the listening room appear very much less important with a stereo reproducer system than with a monaural system. The acoustics of the recording studio are the predominating factor, a point well brought out when listening to the Glyndebourne recordings. Room size also appears to be a less significant factor, very good results being secured in a room only 12ft x 9ft with the speakers across the end of the 9ft wall.

One very important factor is the relative volume level from the two speakers. Any 2-channel stereo system must depend for its main effects on the

intensity difference that is produced at the two ears, the intended result being secured by the correct positioning of the microphones at the recording studio. A reproducer system having separate gain controls in each channel allows the stereo result to be completely spoiled by incorrect setting of the gain controls. The ideal arrangement is undoubtedly to have a single knob with the two channel controls ganged on the same spindle, though each channel must have a separate gain control that can be pre-set to equalize the acoustic output from the two channels. From this point of view it would be a great convenience to have available a "balance tape" with short bursts of 1,000 c/s tone recorded alternately on each track. This would allow the acoustic outputs of the two speakers to be balanced and the gain control settings noted for future use. Such "loudspeaker balance" films are available to the cinema engineer. (A loop of tape only 3 or 4ft long is quite adequate.) The necessity of balancing, in some manner, cannot be too strongly emphasized, for lack of balance leaves the orchestra and all the singers on one side of the room, completely ruining any stereo effects.

The amplifiers used should have similar characteristics, a tolerance of ± 1 dB over the frequency range being suggested. If variable tone controls are fitted these need to be set to give the same overall frequency characteristic, or the orchestra tends to be concentrated towards the loudspeaker having the best high-frequency response. Differences in frequency characteristic of more than 2 or 3 dB lead to a peculiar "stretching" of the orchestra, while the individual instruments move about the stage as the player moves up and down the musical scale.

Finally about the future. In the cinema world stereophonic sound reproduction has been seriously jeopardized by the widespread release of films with identical sounds on all three tracks though advertised as having "stereophonic sound". In many films these have been dubbed on to the magnetic tracks from a single original photographic track. This is killing the goose with a vengeance. It is hoped that no one will attempt to foist such counterfeit on the domestic market.

In my opinion, stereophonic tape recordings of the present standard are sufficiently outstanding to ensure that they will be the accepted practice for all domestic high-quality systems in perhaps a couple of years time. Cost remains an obstacle at present, but it is to be hoped that prices will fall steeply as the demand rises.

APPRENTICESHIPS

AN outline of the opportunities open to graduates and others in the Philips organization in this country is given in "Careers in Philips." It covers mainly the opportunities in the manufacturing organization but also touches upon the openings for technical staff in the commercial departments.

Two brochures available from Metropolitan-Vickers cover the apprenticeships which the company offers to graduates ("The Training of the Professional Engineer") and public, secondary grammar and technical schoolboys ("From School to Professional Engineering").

"Opportunities in Electronics for University Graduates" is the title of a booklet issued by Mullard. It outlines the opportunities open to science graduates in the company's research laboratories and production organizations.

Transistor R.F. Amplifiers

2—PRACTICAL CIRCUITS WITH NEUTRALIZATION AND AUTOMATIC GAIN CONTROL

By D. D. JONES,* M.Sc., D.I.C.

(Concluded from page 496 of October issue)

IT was mentioned in Part I, last month, that if a voltage appears at the output terminals of a transistor amplifier, internal feedback due to r_{bo} and C_c results in a voltage also appearing at the input terminals. Consider a common-base amplifier working into a load Z_L . If an a.c. current I is made to flow in the input circuit a voltage approximately equal to $\alpha I Z_L$ will appear across Z_L ; the phase relationship between this and the applied signal will depend on the phase change introduced by the complex nature of α . Part of this voltage will now be fed back into the input circuit via C_c and r_{bo} and will modify the input impedance of the amplifier; the extent of this modification depends on the

magnitude of Z_L as well as on α , C_c and r_{bo} . The input impedance does therefore depend on the load; as was mentioned in the introduction this effect does not arise in thermionic valves until the frequency is comparatively high.

If a tuned circuit forms part of the load, Z_L will vary with frequency; this can give rise to considerable variations in input impedance over the bandwidth of the tuned circuit (and hence, of the amplifier). It is desirable to introduce a subsidiary network into the amplifier circuit to produce another feedback component which cancels out that produced by the transistor.

Neutralizing networks of this kind play an important part in present-day transistor circuits.

There are a number of possible neutralizing arrangements, but so far only two or three of them have been extensively used. A useful method both for seeing the necessity for neutralization, and also for aligning the circuit itself, is to measure the input impedance of an amplifier as a function of frequency over the pass band; the amplifier load includes the tuned circuit in these measurements.

In the common-base amplifier the input impedance can increase to very high values in the pass band; it can in fact become infinite, change its sign and give rise to oscillations. In the case of the common-emitter amplifier, the input impedance decreases over the pass band and can again become negative and cause oscillations. In properly neutralized amplifiers there should be no significant changes of input impedance over the pass band.

The circuit shown in Fig. 5 is found to be satisfactory for neutralizing the common-base amplifier. Any voltage appearing across the output terminals will give rise to a voltage across the input terminals due to internal feedback provided by r_{bo} and C_c ; however, a voltage will also be fed back into the input terminals via C_n and r_n and if

$$r_n C_n = r_{bo} C_c$$

these fed back voltages will be equal and will cancel each other out.

The circuit shown in Fig. 6 can be used for the common-emitter amplifier. In this case the capacitance C_c feeds a voltage back into the input circuit; by means of the phase inverting transformer and the capacitor C_f , an out-of-phase voltage of equal amplitude is also applied to the input circuit. The effectiveness of this method depends on r_{bo} being low. A more satisfactory result can be achieved if the circuit of Fig. 7 is used; however, since r_e varies rapidly with emitter bias current it is found that this bias must be kept reasonably constant for the method to be effective.

Any practical amplifier is expected to give satis-

* Research Laboratories, The General Electric Company.

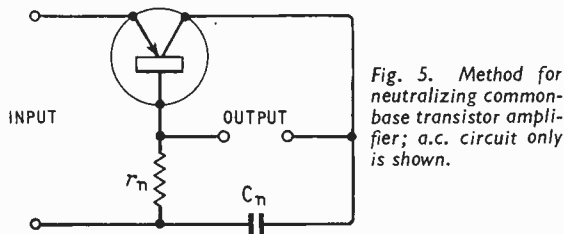

Fig. 5. Method for neutralizing common-base transistor amplifier; a.c. circuit only is shown.

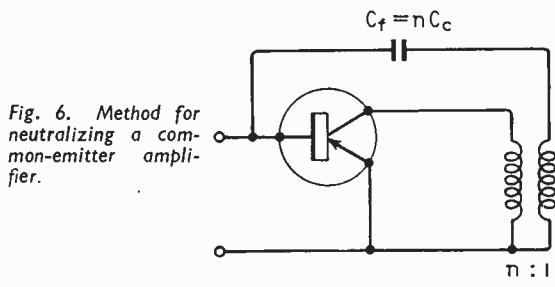

Fig. 6. Method for neutralizing a common-emitter amplifier.

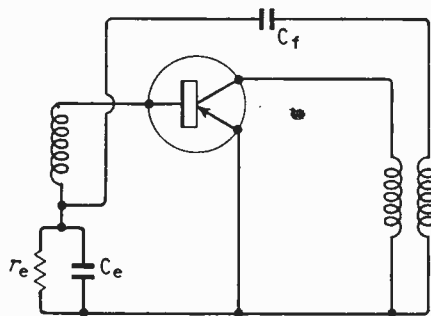

Fig. 7. Method similar to that shown in Fig. 6, but with r_e and C_e taken into account.

factory performance over a range of operating conditions. A fair test of the performance of any neutralizing circuit, therefore, is to observe its variation with operating conditions, e.g., with change of supply voltage.

When using GET4 transistors in 465-kc/s i.f. amplifiers, it is found that the common-base circuit with the neutralizing method shown in Fig. 5 can withstand large changes in supply voltage. It is also found that the amplifier is more stable if $r_n C_n$ is slightly less than $r_{b_o} C_c$; using the mean values of r_{b_o} and C_c , obtained from the production "spread" of the transistor, is also found to be adequate.

The higher the dynamic impedance of the tuned circuit used, the more critical does the design of any neutralizing network become.

Fig. 8 shows a two-stage 465-kc/s i.f. amplifier using GET4 transistors. A dynamic impedance of about $50k\Omega$ is used in this case to avoid the necessity for very accurate neutralization. A gain of about 36dB is obtained with such an amplifier. This gain is considerably lower than would be obtained if transistors having much higher M_o were used; however, it does show that using transistors in what are undoubtedly "marginal" circuits, useful gain can be obtained if neutralization is employed.

In order to obtain as much gain as possible it is necessary to use interstage transforming circuits. The transformation ratio depends on the dynamic impedance of the tuned circuit forming the collector load of one transistor and the input impedance of the next stage. In the amplifier shown in Fig. 8 a turns ratio of about 20:1 is used, though this could be increased at the expense of rather more critical neutralization.

Of the various types of matching circuits that can be used, that shown in Fig. 9(a) is widely employed in practice. In experimental work the circuit of Fig. 9(b) is often useful.

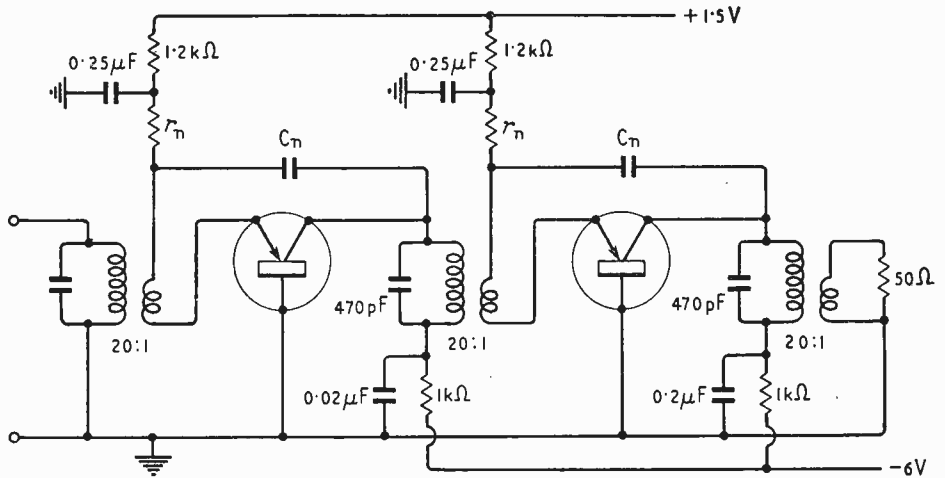

Fig. 8. A two-stage 465-kc/s i.f. amplifier using GET4 transistors.

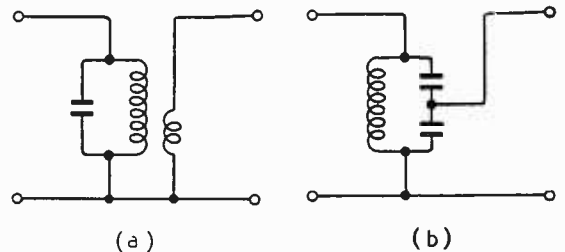

Fig. 9. Interstage coupling networks.

Since C_c and C_n form part of the tuned circuit it is important to remember that C_c varies with supply voltage. To minimize this effect, the tuning capacitor should be large.

It is often desirable that the gain of an amplifier can be automatically adjusted according to the mean level of the input signal. Unless the gain is controlled in this way the amplifier may be overloaded at high levels of input signal.

Automatic gain control can be achieved in two ways. In the first method, the actual d.c. voltage at the collector is reduced as the mean signal level increases; both the current gain factor and the collector capacitance vary with collector voltage and contribute to a reduction in the gain of a tuned amplifier. The second method is based on reducing the emitter bias current as the mean signal level

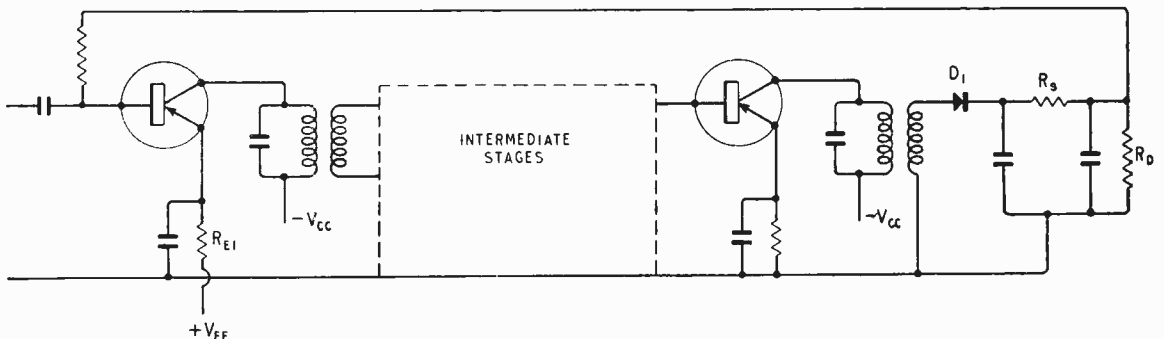

Fig. 10. Automatic gain control of a common-emitter amplifier.

increases; this technique is used more extensively than the former and is therefore discussed in greater detail.

In Part I of the article it was mentioned that the input impedances of the common-base and common-emitter amplifiers, when working into low load impedances, are given by

$$Z_{in} = r_e + r_{bo} (1 - \alpha) \text{ for common-base.}$$

$$Z_{in} = r_{bo} + \frac{r_e}{1 - \alpha} \text{ for common-emitter.}$$

(C_e being ignored for the moment). When the load impedance is comparatively high it is found that the parameter r_e still plays a dominant role in the expression for input impedance. It was also mentioned earlier that r_e is inversely proportional to the emitter bias current I_e . If this current is varied Z_{in} will be varied in both amplifiers.

The emitter bias current, I_e , is related to the base bias current, I_b , by the expression

$$I_e \sim \frac{1}{1 - \alpha} I_b$$

Since $1/1 - \alpha$ is, typically, 40 it will be seen that large changes in I_e and hence in r_e can be achieved

by small changes in I_b . In both common-base and common-emitter amplifiers it is general to arrange the d.c. bias circuit so that the value of I_b can be varied.

Fig. 10 shows a circuit used experimentally for providing a.g.c. In this, the output from the amplifier is rectified by diode D_1 to give a positive output voltage. This is then fed back to the base of the first amplifier and reduces the base bias current (which is negative in sign). The emitter resistor R_{E1} should be as low as possible because it produces an undesirable increase in the d.c. input resistance of the amplifier; the a.g.c. may be regarded as being substantially d.c. The resistance of R_D is made fairly large ($\approx 20k\Omega$) and, as a result, much of the positive bias voltage V_{EB} is developed across it. This biases the diode in the reverse direction, thereby giving rise to a delayed a.g.c. characteristic. As the signal input to the diode is increased, the positive voltage between emitter and base, and hence the gain of the amplifier, is reduced.

In amplifiers where a transistor is used as a second detector a similar principle can be employed to obtain a.g.c.

BOOKS RECEIVED

Radio Research 1955. Report of the year's work by the Radio Research Board (D.S.I.R.), which included phase changes in ground waves of low frequency, propagation at v.h.f. and u.h.f. (including direction finding at these frequencies), measurement of atmospheric noise and investigation of ferrite and semi-conductor materials. Pp. 56; Figs. 8. Price 3s 6d. Her Majesty's Stationery Office, York House, Kingsway, London, W.C.2.

Automatic Integrator for Determinating the Mean Spherical Response of Loudspeakers and Microphones by A. Gee, M.A., and D. E. L. Shorter, B.Sc.(Eng.), A.M.I.E.E. No. 8 in the series of Engineering Monographs published by the B.B.C. describes the use of a modified kilowatt-hour meter for integrating the response while plotting the polar diagram on an automatic recorder. Pp. 16; Figs. 10. Price 5s. B.B.C. Publications, 35, Marylebone High Street, London, W.1.

Frequency Modulation Engineering by Christopher E. Tibbs, M.I.E.E., M.Brit.I.R.E., and G. G. Johnstone, B.Sc. Revised second edition of a comprehensive survey of the principles and practice of transmitting and receiving f.m. signals. Includes mathematical treatment to the level required for the design of components and systems. Pp. 435; Figs. 254. Price 45s. Chapman and Hall, 37, Essex Street, London, W.C.2.

Radio (Vol. 3) by J. D. Tucker and D. F. Wilkinson, B.Sc.(Eng.), A.M.I.E.E. Text book covering the syllabus of the Radio III examination of the City and Guilds of London Institute. Pp. 249; Figs. 237. Price 12s 6d. English Universities Press, Ltd., 102, Newgate Street, London, E.C.1.

Radio Servicing (Vol. I. Electrotechnology) by G. N. Patchett, B.Sc., Ph.D., M.I.E.E., M.Brit.I.R.E. Fundamental electrical concepts underlying the theory and practice of radio (including television) servicing. Designed to cover the syllabus of the City and Guilds and R.T.E.B. examinations. Pp. 80; Figs. 84. Price 5s. Norman Price (Publishers), Ltd., 283, City Road, London, E.C.1.

Hi Fi Loudspeakers and Enclosures by A. B. Cohen. Lucidly illustrated analysis of the construction and

principles of operation of loudspeakers, cabinets and folded horns (principally of American design and manufacture) with an appendix giving constructional details of 18 representative types. Pp. 360; Figs. 183. Price 37s 6d. Chapman and Hall, 37, Essex Street, London, W.C.2.

Introduction to Colour TV M. Kaufman and H. E. Thomas. Second edition of a general description of the NTSC system with stage-by-stage analysis of a receiver and a full circuit diagram. Pp. 156; Figs. 81. Price 25s. Chapman and Hall, 37, Essex Street, London, W.C.2.

Mandl's Television Servicing by M. Mandl. Revised second edition of a teaching manual for students with new material on transistors and printed circuits. Illustrated by examples from American practice. Pp. 460; Figs. 314. Price 45s 6d. The Macmillan Company, 10, South Audley Street, London, W.1.

An Approach to Modern Physics by E. N. da C. Andrade, D.Sc., Ph.D., LL.D., F.R.S. Non-mathematical survey for the layman of recent developments in theoretical and experimental physics. Pp. 232; Figs. 7 and 16 plates. Price 25s. G. Bell and Sons, Ltd., York House, Portugal Street, London, W.C.2.

From Microphone to Ear by G. Slot. Philips Technical Library Popular Series introduction to modern sound recording and reproducing technique. Deals primarily with disc recording but includes a chapter on magnetic tape. Pp. 169; Figs. 118. Price 17s 6d. Cleaver Hume Press, Ltd., 31, Wrights Lane, London, W.8.

Les Antennes by L. Thourel. Comprehensive mathematical treatise on aerials with particular emphasis on decimetre and centimetre wavelengths. Includes chapters on horns, slots, and lenses. Pp. 440; Figs. 252. Price 4,800 Fr. Dunod, 92 rue Bonaparte, Paris, 6.

Informationstheorie Vol. 3 of "Nachrichtentechnische Fachberichte." A collection of 12 papers by authors of many nationalities on applications of information theory, with summaries in English and German. Pp. 118; Figs. 125. Price 16.50 DM. Verlag Friedr. Vieweg and Sohn, Postfach 185, Braunschweig, Germany.

The Second International Congress on Acoustics was held at Cambridge, Massachusetts, in June this year in conjunction with the Annual Meeting of the Acoustical Society of America. These Congresses, which are sponsored by the International Commission on Acoustics, one of the specialized commissions of the International Union of Pure and Applied Physics under UNESCO, are being held at intervals of three years. The first was held at Delft in 1953.

International Acoustics Conference

Some Impressions of this Year's Meeting in the U.S.A.

FROM A CORRESPONDENT

THE opening ceremony and the first two days' technical sessions were held at the Massachusetts Institute of Technology. The following two days' technical sessions took place in Harvard University and the fifth and final days' meetings were again at M.I.T. In addition to the technical sessions, some visits, a concert and a banquet were arranged for the delegates.

The meetings at Harvard were of particular interest because of the associations with W. C. Sabine who originally postulated the concept of reverberation time. Some of the meetings were held in the Sanders Theatre which was one of the auditoria in which he conducted his experiments. His original reverberation chamber was on view, as were some of the famous cushions which he used in providing absorption experimentally. The concert was given by the Boston Symphony Orchestra in the Boston Symphony Hall which is an important acoustic design by W. C. Sabine.

Because this Congress was held in conjunction with the Annual Meeting of the Acoustical Society of America the attendance was much greater than at Delft. In all there were about 900 delegates and almost 300 papers in various classifications. In addition to the delegates there were, of course, associates, bringing the total to the region of 1,200. The variety of papers was great, covering all the aspects of acoustics. Typical classifications were as follows:—

- Architectural Acoustics
- Musical Acoustics
- Speech Analysis and Synthesis
- Physical Acoustics and Sonics
- Loudspeakers and Sound Reproduction
- Noise Control and Measurements
- Bioacoustics
- Geophysical Acoustics
- Radiation and Scattering of Sound

On the evening of the first day a demonstration of speech analysis and synthesis was given by W. Lawrence of S.R.D.E., which was exactly similar to the demonstration he has already given in this country to the I.E.E. and to the Acoustics Group of the Physical Society. Following this another demonstration of speech synthesis was given by G. Fant of Stockholm which, although in some respects it did not reach the standard of the S.R.D.E. demonstration, appeared to indicate a more flexible system

which might be capable of great development. A very humorous finale to these demonstrations took the form of a duet sung by both pieces of equipment.

For the benefit of all the delegates, a survey paper was read by Georg von Békésy on the mechanics of the cochlea. Békésy, who has now worked at Harvard University for many years, is well known for his investigations into the theory of hearing.

In the field of loudspeakers and sound reproduction various interesting papers were read. For example, papers were given on "Directional Loudspeakers for Sound Reinforcement" by S. Hill (S.T.C.); "The E.M.I. Stereo Recording and Reproducing Systems" by G. F. Dutton; "Displacement Pickup for Measuring the Motion of a Loudspeaker Cone at Many Points" by K. R. McLachlan. A paper was also read on the latest apparatus for the alteration of the playback time of a sound record by A. M. Springer, who now claims that this equipment, which is basically similar to the "Ton-schreiber B" used by the Germans during the war, can expand the time of reproduction of speech and music by as much as 200 per cent and give satisfactory compression of 50 per cent. An interesting paper was read by R. Kirk on "Learning, A Major Factor Influencing Preferences for High-Fidelity Reproducing Systems". This paper describes an attempt to evaluate the effect of experience on the opinions of subjects listening to high-quality electro-acoustic reproducing systems. Two groups were used; one listening to music reproduced between 30 and 15,000 c/s, while the other group listened to 180-3,000 c/s. After they had listened for two hours a week for 13 weeks, tests were carried out which seemed to show that the subjects preferred the particular bandwidth to which they had been listening.

Papers on architectural acoustics reflected the work going on at present to provide effective objective means for measuring the properties of enclosures, but developments are so slow that it will be many years before complete reliance on objective methods will enable satisfactory designs to be carried out.

In the field of musical acoustics several papers described methods of synthesizing sounds, which in some cases were intended to represent normal musical instruments and in other cases to produce sounds entirely different. Some workers are con-

BRITISH AMATEUR TELEVISION STATIONS

Call sign	Location	Vision		Sound Frequency (Mc/s)
		Frequency (Mc/s)	e.r.p.	
G2WJ	Dunmow, Essex ...	436.0	250W	432.5 or 145.3
G3GDR	Abbots Langley, Herts.	434.1	250W	434.1 or 144.7
G2DUS	Baldock, Herts.	434.5	250W	434.5 or 144.5
G3KKD	Ely, Cambs. ...	434.1	2W	434.1
G3KOK/T	Bishops Stortford, Herts ...	437.0	60W	433.5
G3CVO	Chelmsford, Essex ...	430.36	200W	426.86 or 1.97
G3KBA/T	Birmingham, Warwick.	436.8	50W	
G3BLV	Sunderland, Durham	435.1		
G5ZT	Plymouth, Devon ...	427.0	50W	
G3WFF	Belfast, N. Ireland ...	437.75		434.25
G3CTS	Norwood, London ...	427.0	1kW	423.5
G3KRA/T	Chelmsford, Essex ...	442.0	2W	438.5
G3KQJ/T	Wolverhampton, Staffs.	438.75		435.25
G3KFE	Enfield, Middx. ...			
G3JVO/T	St. Albans, Herts. ...	445.5	10W	
G3BAY	Leicester ...			
G3FNL	Upminster, Essex ...	445.0	250W	441.5
G3KPX/T	Maidenhead, Berks. ...			
G3AST	Luton, Beds. ...	434.25	50W	144.75
G3KFH/T	Worthing, Sussex ...	433.0	50W	
G3ACK	Blyth, Northumb. ...	432.6		
G3LCM/T	Coulsdon, Surrey ...			
G3LDW/T	Birmingham, Warwick.	434.7	25W	

Amateurs with a general transmitting licence add the suffix "/T" when transmitting television.

mitted in the 430-440 Mc/s region, with the sound channels, normally duplex, on lower frequency amateur bands such as 1.9 Mc/s or 145 Mc/s. Attempts to space the sound channel the correct 3.5 Mc/s below the vision carrier are only successful over the better paths, as otherwise the loss of vision signal-to-noise ratio is too great to be tolerated as the receiver bandwidth is increased. To overcome this, and for weak-signal reception generally, it is becoming common to lock the amateur TV equipment to B.B.C. or I.T.A. synchronizing pulses at each end of the path; considerably weaker signals can then be resolved quite easily.

There are now 23 amateur television stations licensed, and 14 of these have actually radiated pictures. In Birmingham, G3KBA/T is in a very bad location, surrounded by tall steel-framed buildings, and in order to send pictures from his 16mm telecine scanner to G3KQJ/T at Wolverhampton, a relay via a nearby station is necessary. G3KFH/T at Worthing has put out some test transmissions, and hopes to send pictures across the channel. With G3BLV/T (Sunderland) and G2DUS/T (Baldock) thinking in terms of portable television transmitters, no doubt the present record of 38 miles will soon be broken.

As was to be expected, the photo-conductive pick-up tube has replaced all other camera tubes as the first choice for the amateur, on account of its sensitivity, small size and modest power and scanning requirements. Cameras are built along similar lines to industrial TV cameras, often with lens turrets and built-in viewfinders for which second-hand projection tubes run at reduced e.h.t. are popular. Existing cameras of the image iconoscope and image orthicon types are still used, of course, but their size is a distinct disadvantage in the average small workshop. Some surplus American airborne TV cameras have also been used with success, but the tube sensitivity is very low. With photo-conductive tubes, normal room lighting is usually sufficient to produce excellent pictures.

Flying-spot scanning remains the standby for most amateurs; newer blue-trace c.r. tubes enable first-class pictures to be produced for a very small outlay. Tubes in domestic television sets can be pressed into service to give fair results, and considerable attention has been given to the problem of scanning cine film. Thus one 16mm scanner consists of an unmodified Kodascope projector, with a 9-in MW22-14 tube as the scanner, using a 4in by 3in raster. The projector is driven by a synchronous motor, but asynchronous running is possible with slight flickering. A 931A photocell is used, with gamma correction in the video amplifier to correct for receiver tube characteristics. More favoured are the types of scanner in which the film is wrapped round a glass or perspex polygon in the same way as in a simple film editor. This system has the very great advantage for the amateur that a picture is produced at all film speeds without any synchronizing troubles. Scan reversing switches are normally fitted for quick saving of face when the film has been incorrectly loaded! For those with photo-conductive-tube cameras, the problem is much simpler; with the camera pointed at the projector (suitably dimmed), very reasonable pictures are produced with no synchronization whatsoever.

Miniaturization and economy in components are pressed to the limit, and several members are using

a simple frame pulse of one half-line duration rather than the full B.B.C.-type waveform. For the latter, some 14 valves are usually required, and the possibilities of transistors are beginning to be explored. As an idea of the size of a typical amateur TV equipment, it may be mentioned that G2DUS/T (Baldock, Herts) has in a rack 36in high by 15in wide the following units: 405-line sync generator, 45-Mc/s oscillator and distribution amplifier, vision mixer, Staticon camera control unit, monoscope unit (Test Card C) and pattern generator, and power supplies. The camera is 10in long by 4in wide and 6in high, and is fitted with 75mm, 35mm and 25mm lenses. With the addition of a domestic TV receiver, a complete closed circuit television station is available.

With a view to informing and instructing amateurs in the problems of television transmission, booklets, a film and six instructional tape lectures have been produced. In addition, B.A.T.C. groups have been formed in Southampton, Worthing, North and South London, High Wycombe, Romford, Chelmsford and Birmingham, where meetings are frequently held. There is little doubt that we are in this country well ahead of everyone else in this particular field, although there are active enthusiasts in the U.S.A., the Netherlands, South Africa, Australia and New Zealand.

Future developments are difficult to prophesy; a link between London and Birmingham, and between the United Kingdom and the Continent, are obvious targets. In the meantime experiments continue with a microwave link, pulsing banks of fluorescent coloured tubes for frame-sequential work in colour, simpler sync generators, better film scanners and more effective transmitters and receivers. No doubt when G3CTS/T, the station of the Television Society, at Norwood, starts regular transmissions this autumn, more and more people will be tempted to try it for themselves.

A representative selection of the equipment mentioned in this article will be shown in operation at the third Amateur Television Convention to be held on October 27th at the Bonnington Hotel, Southampton Row, London.

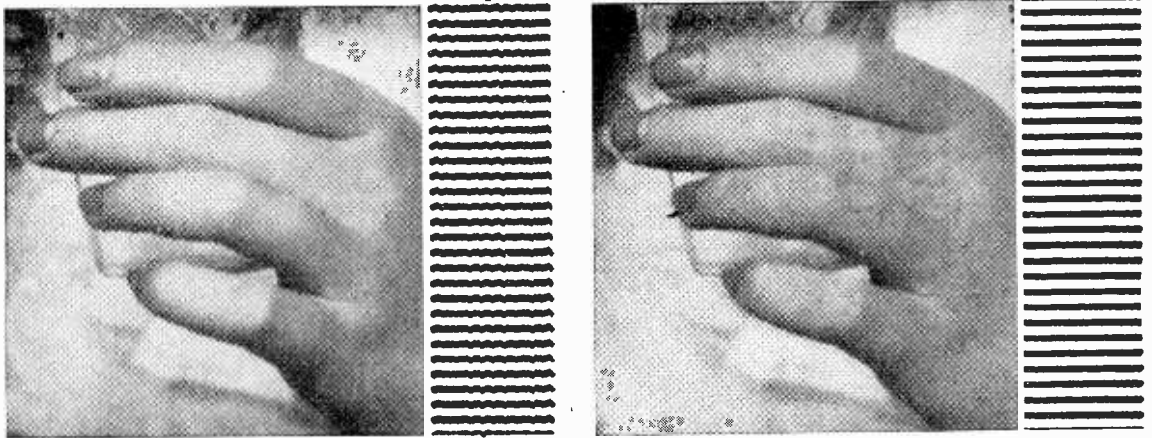

Fig. 1. The effect of insufficient tape speed control is shown at (a) both on the received picture itself (a small section) and on the horizontal test bars to the right. At (b) is shown the improvement effected when the control equipment is in operation

RADIO PICTURES ON TAPE

DURING the Olympic Games this winter, some of the news pictures arriving from Australia by radio phototelegraphy are likely to have undergone the intermediate process of storage on magnetic tape. The storage equipment will be operating at Singapore, which is the normal Cable and Wireless relay point on the "eastabout" route between Australia and the U.K. The purpose of the scheme is to facilitate the transmission of pictures when radio conditions are not good enough on both sections of the route simultaneously for direct relaying. Quite often when conditions are good on the first section they are bad on the second, and *vice versa*. With the intermediate storage, however, it will be possible to send a picture from Australia to Singapore even when radio propagation is bad between Singapore and Britain—then to forward it over this second section when the conditions improve.

In the past any storage has been done simply by printing the picture at the relay station and re-scanning it when required. This, however, tended to degrade the picture quality, mainly because of interaction between the two scanning patterns, and Cable and Wireless considered it desirable that the signal itself should be stored, preferably on magnetic tape. Here, the main difficulty arises from possible variations in the speed of the tape. Any such variations between successive scan lines* of the picture produce timing errors, which are particularly noticeable from the ragged reproduction of horizontal edges on the received picture, as shown in Fig. 1(a).

To overcome this problem the Cable and Wireless tape storage equipment incorporates an automatic system of speed control comparable with an a.f.c. loop. This makes use of a stable reference frequency of 2 kc/s from a crystal oscillator, which is recorded on one track of the tape while the other track is taking the incoming picture signal. (An orthodox twin-track tape deck is used, running at 13 inches per second.) On playback this reference frequency

is compared with the original from the oscillator, and any difference resulting from a change in speed is used to produce a correction signal which controls the tape drive until the frequency difference is reduced to zero. Since the picture information on the tape and the reference frequency bear a constant relationship to each other (being recorded simultaneously) any correction applied to one means a correction to the other.

The actual comparison of frequencies is done by an electromechanical system. To begin with, the normal tape-drive motor is replaced by a phonic motor which, for the recording operation, is energized from the 2-kc/s crystal oscillator through a power amplifier. On playback, the recorded reference frequency from the tape and the output from the crystal oscillator are both amplified and used to operate two further phonic motors which drive the two input shafts of a differential gear. The cage, or output shaft, of the differential then rotates with a speed and direction corresponding to the difference between the two input speeds (and hence frequencies).

This "error signal" rotation, amounting to perhaps 1° of angular movement, is used to drive a variable capacitor which controls the frequency of one of a pair of 100-kc/s oscillators in a b.f.o. arrangement. The beat frequency obtained is arranged to be 2 kc/s, and this, after amplification, is used to energize the tape-drive phonic motor. Any error signals from the differential gear will cause this 2-kc/s beat to be varied (a matter of 3 or 4 c/s per degree of angular movement) and as a result corrections are applied to the speed of the tape-drive phonic motor in the right sense to reduce the error signals to zero.

The actual stability of tape speed obtained by this method is ± 1.5 parts in 10^4 over the period of one drum revolution (short-term stability) and better than ± 1 part in 10^5 over the period of a complete picture (long-term stability). Fig. 1(b) shows how the timing errors are reduced and the picture quality is improved compared with (a).

* Which are, of course, vertical on the drum scanning system used and are, in fact, 100 lines to the inch.

Colonial Broadcasting

By JOHN W. MURRAY*

BROADCASTING within the colonies, which has been in operation for not much more than ten years, is posing problems that demand a fairly early solution. The fundamental problem is similar to that which led the B.B.C. and other European broadcasting authorities to introduce a v.h.f. service, although the attendant circumstances are in general very different.

Twelve bands¹ within the high-frequency section of the radio spectrum (3-30 Mc/s) are allocated for broadcasting; some for certain regions and others world-wide. Allowing a "guard" of 5 kc/s at both ends of each band, there is a total available bandwidth of 2,800 kc/s, which, assuming 10 kc/s per channel, provides 280 channels. In order to eliminate "skip" effect close to the transmitting station and to ensure that the greater part of the power radiated is concentrated, as far as possible, within the territory to be covered, it is necessary to arrange for high-angle radiation. This means that, in practice, the maximum usable frequency cannot be higher than the critical frequency.

For the broadcasting services under consideration, therefore, it is unlikely even at periods of maximum sunspot activity that frequencies much higher than 10 Mc/s will be used. The lower limit is imposed by the high noise level below 4 Mc/s. Thus, ignoring all bands above 10 Mc/s, we are left with a total bandwidth for local colonial broadcasting of 1,225 kc/s, providing for only 122 clear channels.

Even supposing that it were possible to achieve complete international agreement on the allocation, clearing and sharing of frequencies (and this, unfortunately, is far from being the case) it is obvious that it is utterly impossible to attempt to accommodate all the required colonial broadcasting stations within the usable part of the h.f. bands. The result of trying to do so is interference on most channels and, moreover, there is no room in the h.f. bands for future expansion. The conclusion to be drawn is that some alternative to the use of short waves must be explored for the efficient internal coverage of individual colonial territories. The obvious alternatives are: medium frequencies and very-high frequencies. The use of medium frequencies, although fairly satisfactory, suffers from two major limitations. First the medium-wave band is relatively uneconomical because of the necessity to use fairly high powers to overcome atmospheric noise, and, secondly, because of the possibility of interference from distant stations after dark. V.H.F. transmissions suffer from neither of these disadvantages.

The use of v.h.f. does, however, suffer from some

important limitations. The first is the lack of cheap receivers, whether f.m. or a.m., battery- or mains-operated. Clearly, if a decision is made in favour of the use of v.h.f. broadcasting in under-developed countries, the change-over from short-wave broadcasting will have to be spread over a period of perhaps five to ten years. It would be preferable, therefore, for a "general purpose" receiver to be made available, providing for reception on short and medium waves as well as on the v.h.f. bands. This would be desirable, in any case, so as to make it possible for listeners to tune to overseas stations as well as to their own domestic v.h.f. channels. At the present time such a receiver would not cost less than £30 and, while this might find a fairly ready

sale in towns, the rural inhabitants with a much lower income would find it quite impossible to afford such a sum. It is thought that a receiver of the type envisaged could be made available much more cheaply than at present if it were possible for

PROBLEMS OF PROVIDING

A

DOMESTIC SERVICE

several colonial territories to co-operate so that an initial order of not less than 30,000 receivers could be placed with a single manufacturer. Preliminary discussions have already taken place on this subject with one manufacturer. The servicing of the sort of "combination" receiver suggested might conceivably present major difficulties, particularly if it were decided to use a frequency-modulated v.h.f. system. More complicated test equipment and much greater knowledge and skill would be required to service such receivers compared with the "rule-of-thumb" servicing of a medium-wave or even a medium- and short-wave receiver. A further limitation to the use of both v.h.f. and m.f. broadcasting, particularly in large colonial territories without reliable internal telephone communications, is the problem of expense in supplying programmes to each transmitter. Granted that much could be done to solve this by careful siting and design of aerials (more particularly with v.h.f.), so that some transmitters would also form part of the programme distribution chain.

To summarize, it is certain that there can be little expansion of domestic broadcasting in colonial territories on the h.f. bands, whether by an increase in the number of channels or of the powers used. The alternatives are v.h.f. or m.f. Transmitters for v.h.f. might be considered to have greater range for less power than m.f. transmitters, because of the noise limitation on the m.f. band, and, therefore, be cheaper to run. On the other hand, the use of v.h.f. poses some major problems because of the necessity to provide and service much more complicated receivers. I think that this whole problem of the choice of method of coverage is fundamental to broadcasting in every colonial territory, and that discussions should be held, in the near future, between British radio manufacturers and technical representatives of every colonial territory concerned.

* Nigerian Broadcasting Service.

¹ Broadcasting bands (3-30 Mc/s). Those shared with other services are marked with an asterisk. 3.2-3.4*; 3.9-4.0*; 4.75-4.995*; 5.005-5.06*; 5.95-6.20; 7.1-7.3*; 9.5-9.775; 11.7-11.975; 15.1-15.45; 17.7-17.9; 21.45-21.75; 25.6-26.1.

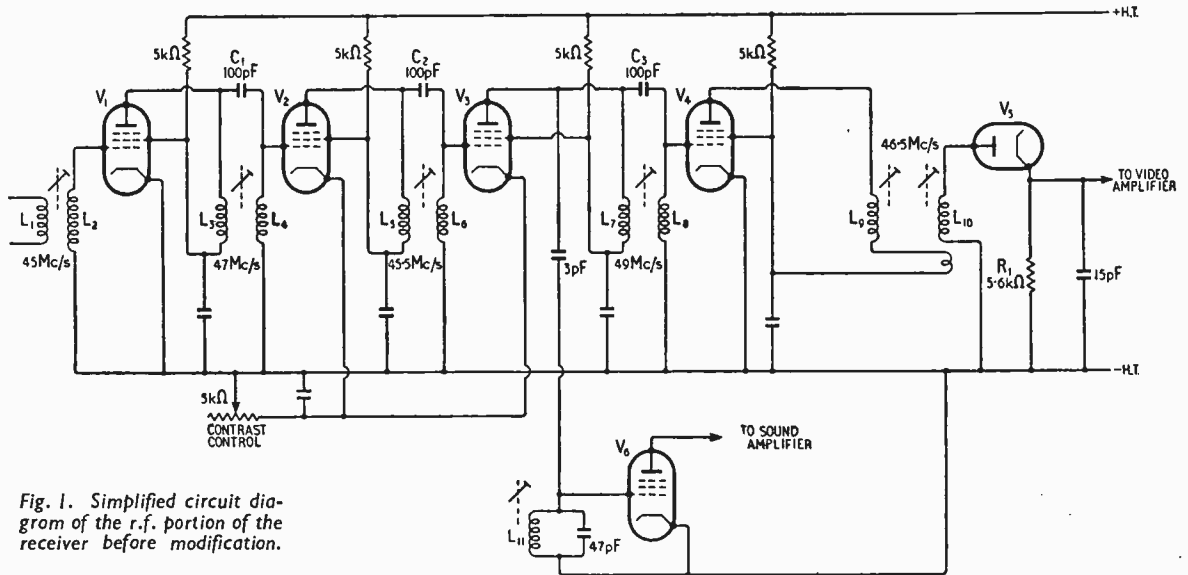

Fig. 1. Simplified circuit diagram of the r.f. portion of the receiver before modification.

Modifying Upper-Sideband Television Receivers

Alterations to T.R.F. Sets for Reception of the Crystal Palace Transmissions

By G. J. CONWAY

A NUMBER of t.r.f. television receivers built to receive the transmissions from Alexandra Palace were designed to accept the upper vision sidebands and are now giving unsatisfactory reception of the Crystal Palace transmissions which have a vestigial upper sideband (up to 750 kc/s). This article describes the modifications which are necessary to obtain good results from such a receiver.

The original decision to tune the vision receiver to the upper sideband was made in order to reduce, as far as possible, breakthrough of sound signals into the vision receiver and of vision signals into the sound receiver. The outermost lower vision sideband is only 0.5 Mc/s from the sound carrier frequency and, in a television receiver designed to accept the lower or both sidebands, the response of the vision r.f. circuits must fall away sharply (by say 40 dB) in this frequency range. Such a response requires the use of at least two sound rejector circuits in the vision receiver. This problem is considerably eased by tuning the vision r.f. circuits to the upper sideband because the separation becomes 3.5 Mc/s, so large that one rejector is usually adequate.

The receiver which was modified was an Alba Model T432, which may be taken as typical of receivers of the upper-sideband type. A simplified

circuit diagram of the r.f. circuits of this receiver before alteration is given in Fig. 1. Of the r.f. circuits L_1L_2 , L_3L_4 , L_5L_6 , L_7L_8 and L_9L_{10} the last is a true bandpass double-tuned circuit but the others are, in effect, single-tuned circuits with a single tuning slug. The top-end capacitors C_1 , C_2 and C_3 are 100 pF each which has negligible reactance at the operating frequency and hence L_3L_5 and L_7 behave as r.f. chokes. Originally these circuits were stagger-tuned to give a passband covering the range 45 to 48 Mc/s, the alignment frequencies being indicated on the circuit diagram. These circuits were retuned by adjustment of the dust-iron slugs to give a passband from 42 to 45 Mc/s. The alignment frequencies are indicated in Fig. 2 and it was necessary to add 5 pF of capacitance to certain of the circuits where the slug adjustment gave insufficient inductance. The passband was checked by a voltmeter connected across R_1 , the vision detector load, the readings being noted whilst a signal-generator output was swept over the frequency range.

After realignment the picture detail was acceptable but, as expected, there was severe breakthrough of sound on vision. The breakthrough of vision signals into the sound receiver was not as objectionable as expected and could be eliminated with some sacrifice in picture detail by careful alignment of the common r.f. stages. The protection due to the sound rejector circuit L_{11} was inadequate and a second (L_{12} in Fig. 2) of similar design was added to V_4 anode. The details of the inductor used are given in the Appendix. The trap is adjusted by means of C_5 to give minimum output at 41.5 Mc/s at the vision detector.

With the addition of the second sound trap, the receiver performed much better, there being no horizontal bars across the picture due to sound break-

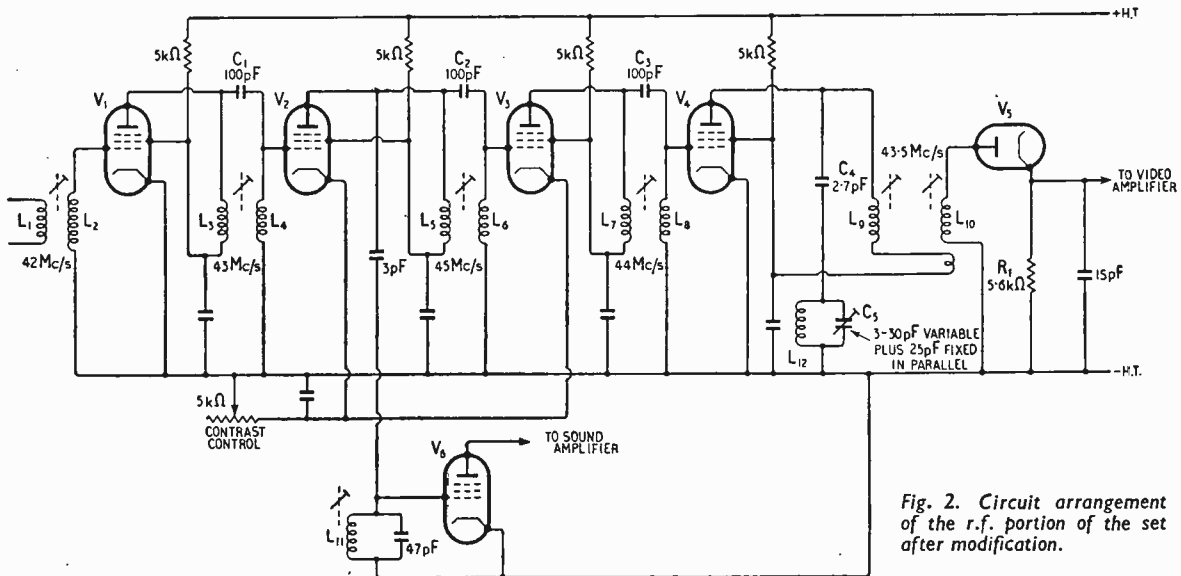

Fig. 2. Circuit arrangement of the r.f. portion of the set after modification.

through. However, there was slight evidence of vision signals breaking into the sound receiver, particularly near maximum or minimum setting of the contrast control. Moreover, there was also visible on the screen a very fine stationary pattern ultimately traced to inter-modulation between the vision and sound carriers. The non-linearity causing this pattern occurred at V₃ grid due to the large sound signal there. The realignment of the common r.f. circuits at a lower frequency had brought about a considerable increase in sound gain and the signal at V₃ grid was large enough to cause cross-modulation. To reduce the sound signal at V₃ grid the sound take-

off point was transferred from V₃ to V₂ anode, which still left more than adequate sound gain but eliminated the sound patterning and a slight tendency towards instability in the sound receiver. A small capacitance (3.3 pF) was required at V₃ anode to make up for the loss due to removal of the sound rejector. After realignment the performance of the receiver was satisfactory.

APPENDIX Details of Sound Rejector Coil L₁₂

10 turns of No. 18 s.w.g. tinned copper wire wound as a self-supporting air-spaced coil of $\frac{1}{4}$ in internal diameter occupying a length of 1 in.

COMMERCIAL LITERATURE

Ionospheric Scatter.—Transmitter of 40kW output, covering 35-55Mc/s, for frequency shift keying of 4-9kc/s. Duplicate r.f. amplifiers, normally operating in parallel, for continuity of service. Double diversity receiver, 30-60Mc/s, with triple frequency changing, using separate "mark" and "space" receiving chains. Leaflet from Marconi's W.T. Company, Marconi House, Chelmsford, Essex.

Communications Receiver, 15-45kc/s and 100kc/s-30Mc/s, with exceptionally long tuning scale of about 4ft for each of seven ranges. Has incremental tuning control over constant 100-kc/s range and incorporates crystal calibrator giving 100-kc/s check points throughout frequency range. Specification on a leaflet from Airmec, High Wycombe, Bucks.

Television Waveform Generator; valve-voltmeter; audio frequency meter; power supply units; and television and f.m. pre-amplifiers and distribution amplifiers. Illustrated catalogue from Channel Electronic Industries, Dunstan Road Estate, Burnham-on-Sea, Somerset. Also a leaflet on a portable **Moisture Meter** with a battery life giving about 10,000 readings before replacement.

Closed Circuit Television Equipment for educational and demonstration purposes. Comprises miniature camera, using 16-mm lenses, portable control equipment using plug-in units, and direct-viewing monitor. Also two projection equipments available for larger audiences. Leaflets from General Precision Laboratory, 431, Fifth Avenue, New York 16, N.Y., U.S.A.

V.H.F. Aerials for television and f.m.; general aerial accessories; connectors; cables; and a range of test gear. Catalogue, including many items of British manufacture, from Rudolph Schmidt, Gl. Kongevej 64, Copenhagen 5, Denmark.

"**Transistors for the Experimenter**" is the title of a new booklet giving application notes and 17 practical circuits

built around the OC70, OC71 and OC72 Mullard types. Characteristics and circuit configuration are discussed, with sections on large- and small-signal a.f. stages, d.c. stabilization of working point, and oscillator and switching circuits. From Mullard, Technical Service Dept., Century House, Shaftesbury Avenue, London, W.C.2.

Impregnation Recording Equipment for use in manufacture of cables, transformers, capacitors, etc. Gives continuous record on paper chart of insulation resistance, self-capacitance (of cables), and temperature and vacuum inside impregnation tank. Leaflet from Addison Electric Company, 10-12, Bosworth Road, London, W.10.

Germanium Diodes and Transistors. Manual giving full characteristics with curves, application notes and specimen circuits of 18 Telefunken types. A power transistor, OD604, when used in a Class B push-pull audio output stages gives 3.5W with a 6-V supply. From Telefunken, Mehringdamm 32-34, Berlin S.W.61, Germany.

Power Supply Units, voltage regulated, for 105-125V, 60c/s. Have recovery time of less than 50μsec and are suitable for square wave pulsed loading. Voltage range continuously variable, and either positive or negative may be earthed. Leaflet from Kepco Laboratories, 131-138, Sanford Avenue, Flushing 55, N.Y., U.S.A.

Projection Television Screen, 24in × 18in, for use in larger receivers (back projection type) in schools, hotels, clubs, etc. Made of plastic material and has Fresnel and lenticular patterns embossed, as in smaller types. Leaflet from Mullard, Century House, Shaftesbury Avenue, London, W.C.2.

Magnetrons and Travelling-Wave Tubes. Theory of operation, performance characteristics, application notes and techniques for measuring important electrical parameters are given, as well as data on commercially available types, in a booklet from R.C.A. Great Britain, Lincoln Way, Windmill Road, Sunbury, Middlesex, price 4s 6d.

The Great Transistor Chaos

IT is sometimes said that one doesn't have to know how a transistor works in order to be able to use it. In a sense, that is true; but it is as well to consider what sense. For instance, what is meant by "using" a transistor?

In one sense, all the people who are going to buy transistorized portable sets will be using the transistors contained therein. Obviously they will not find it necessary to take a course on the physics of semi-conductors in order to be able to do so. Most of them will know nothing whatsoever about how transistors work, and probably would not recognize one if they saw it. In the same sense, users of motor vehicles would include passengers, who in that capacity secure no appreciable advantage from a study of thermodynamics.

But it is rather different for those who drive. Though it is true that very many motorists have only the haziest idea of the means by which their operation of the controls achieves the desired results, this is regrettable; to get the best out of a machine, intelligent understanding is better than memorized rules. It would, however, be pressing the point rather far to insist that drivers ought to be competent in the theory of thermodynamics as well as in practical mechanics. But when we come to a third class—those who design the things—practical mechanics might be enough for turning out some sort of vehicle, but certainly not a good one by present standards.

Too Many Data?

I assume that *Wireless World* readers are not content just to listen to transistor radio, or even to control it, but want to apply transistors to their own problems without having to receive word-by-word instructions. In my view, it is not enough to regard transistors as little three-terminal boxes having certain characteristics as set forth on the makers' data sheets. Without at least a rough idea of their internal electronics, one is quite likely to ruin them at a very early stage of the practical proceedings. In any case, a willingness to accept them as boxes of mystery is surely rather a poor state of mind¹

Hence my recent efforts* to impart the aforesaid rough idea.

The next step is to learn what the makers' data mean. And that is where trouble really begins. If, when studying the electronic side of the subject, one finds the Fermi levels and Pauli exclusion principle too much, one can always give up; such knowledge, though desirable, is far from necessary for ordinary purposes. But if one is in a state of confusion about transistor characteristics, that state is bound to affect everything from there on.

The full extent of the difficulty may not appear at first sight. After all, having learnt what transistors are, one is prepared for their characteristics to be a little more complicated than a valve's. Looking at the first data sheet we find α , the current amplification. That is all right; we know that a transistor is basically a current amplifier, so it is natural to have this α in place of a valve's μ . Then instead of

the familiar r_a there are four resistances: r_e , r_b , r_c and r_m . Well, we have been prepared for the fact that the input electrode of a transistor, unlike the biased grid of a valve, is highly conductive, so it is natural for there to be a r_b (presumably base resistance) or—and possibly and— r_e (emitter resistance) as well as r_c (collector resistance). But what is r_m ? Something analogous to $1/g_m$? Certainly all these resistances are going to make transistor calculations more complicated than valve calculations. And of course there are the alternative methods of connecting it, resulting in widely different amplification factors such as α and α' . Come to think of it, though, the effective μ of a valve is also altered very much if the valve is connected as a cathode follower instead of with the more usual earthed cathode; so that is no new complication.

Thus we may comfort ourselves.

Then we look up another data sheet and find a set of completely mysterious quantities called h_{11} , h_{22} , h_{12} and h_{21} , to say nothing of h_{11}' , h_{22}' , h_{12}' and h_{21}' . And that is far from all. We look up a book to get a bit of know-how, and discover that it prefers to deal in r_{11} , r_{22} , r_{12} and r_{21} , which are not (as we had dared to hope) just different symbols for the same things. Worse still; in another book—or perhaps the same one—we encounter g_{11} , g_{22} , g_{12} and g_{21} . And we learn that the foregoing r and g groups apply only at low frequencies and really ought to be the "complex" quantities z and y . And another book, while using the known r_e , r_b , r_c and r_m , also throws in r_d . And while one technical periodical extols the merits of r_{in} and r_{out} in place of r_{12} and r_{21} , another advocates a "reverse current amplification," β . And when we come to equivalent circuits for the transistor (to compare with the two alternative kinds we know for the valve) we find that one book alone† shows dozens of different varieties, merely as samples of many more!

Before you instruct your newsagent to stop the *Wireless World* and decide to seek admission to the Royal Horticultural Society instead of the I.E.E., may I prevail upon you to do nothing rash. I entirely agree with you that the situation just outlined is one which would excuse, if not justify, a breach of the peace or other departure from normal civilized behaviour. Nor am I able to offer any hope that its obscurities can be dispelled by a few crisp words of explanation. But although there is something to be said for every one of these systems, in the course of time the principle of survival of the fittest will presumably operate; and meanwhile there exist tables for "translating" transistor data from one system to another.

I feel we would be better equipped to find our way through this rank technical jungle if we turned back to review what was done with the valve. This is the approach adopted by W. T. Cocking in his excellent series "Transistor Equivalent Circuits," in the July to October issues last year. Part 1 of that series, in fact, is devoted entirely to the valve; and I recommend you to read (or re-read) it before going any further—even though he did adopt the opposite

*In the July to September issues inclusive.

†"Transistor Electronics," by A. W. Lo and others. (Prentice-Hall, Inc.)

convention to the one I favour[†] with regard to the direction of anode current. He had a good reason for doing so, because instead of beginning with the usual "small signal" or a.c. equivalent circuit (which might have puzzled beginners unused to the idea of neglecting such things as h.t. and grid bias sources) he started from the static or d.c. characteristics and thereby was logically almost obliged to decide on the direction of the anode current as being the same as the d.c. component supplied by the h.t. source, even though that source forms no part of the purely a.c. equivalent circuit and its intrusion conflicts with the usual convention of reckoning voltages relative to the cathode. Here, for brevity, I must assume that everyone who had not already grasped the idea of omitting the d.c. parts in an equivalent circuit has made good that deficiency by learning from Mr. Cocking.

And since this subject is complicated enough at the best, I am going to restrict it to (1) triodes (three-electrode valves and transistors) and (2) low-frequency operation (ignoring electrode capacitances,

hole storage, and other high-frequency effects). It is, of course, assumed that operation of both valves and transistors is confined to nearly linear parts of their characteristic curves and that, owing to appropriate negative bias, valve grid current is negligible.

Because of this absence of grid current, there is only one current path through the valve—between cathode and anode. The current through this path depends on the voltage across it, just as with any resistor. It also depends on the grid voltage relative to the cathode, but if we wish we can exclude that from the problem by short-circuiting it to cathode, as in Fig. 1(a). So far as a.c. is concerned, the valve so connected behaves as a resistor of approximately constant resistance, which is customarily denoted by the symbol r_a . The equivalent circuit of the valve is therefore as shown at (b). The value of r_a is invariably included among valve data. It can be measured in the same way as any other a.c. resistance, if provision is made for the appropriate d.c. through the valve. Alternatively its value can be derived from the slope of the anode-current/anode-voltage characteristic curves within suitable limits; e.g., if an additional 15V is needed to increase the anode current by 1mA, then $r_a = 15/0.001 = 15,000\Omega$ or 15k Ω .

[†]"The Valve 'Equivalent Generator,'" *Wireless World*, April 1947.

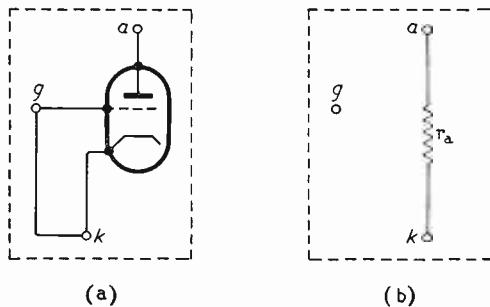

Fig. 1. (a) represents an actual valve, with its grid signal voltage relative to cathode kept at zero by short-circuiting g to k . (b) is the equivalent circuit of the valve under these conditions; it can be substituted for (a) for purposes of a.c. signal calculations.

A Familiar "Equivalent"

The next step is to represent what happens when the grid voltage is variable. The means of varying it is shown in the valve circuit diagram, Fig. 2(a), as a generator giving an alternating voltage v_{kg} . Note that this symbol signifies the e.m.f. in the direction k to g , which means that when it is positive it makes g positive (relative to k , which is reckoned as zero potential). Again, the valve—the part of the diagram within the dotted line—can for purposes of calculation be replaced by the equivalent circuit, Fig. 2(b). The influence of v_{kg} is represented here by a generator in series with r_a delivering a voltage $-\mu v_{kg}$, where μ is the universally accepted symbol for the valve's voltage amplification factor, equal to the number of anode volts that have to be applied to offset minus one grid volt. This too can be measured, or derived from sets of characteristic curves which show the effects on anode current of both anode and grid voltage. Because there is no grid current the grid terminal in the equivalent diagram is not connected internally, and indeed is often omitted, except in diagrams where inter-electrode capacitances are taken into account.

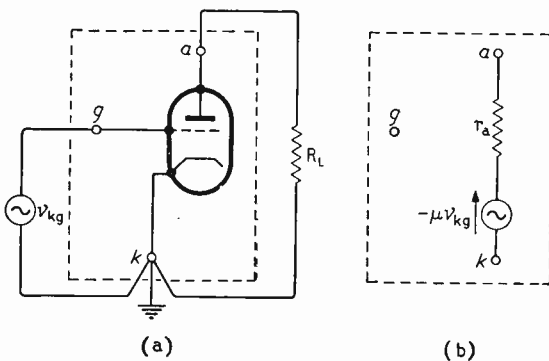

Fig. 2. (a) The essentials (so far as a.c. is concerned) of the most familiar basic type of valve circuit, in which the input (a signal source) is connected between g and k , and the output (a load resistance) between a and k . (b) The valve equivalent.

A valve is normally connected at two points to an input and at two to an output, making four connecting points altogether; but as there are only three electrodes one electrode must be common to both input and output, being joined to them either directly or through negligible a.c. impedance. In each case it is the low-potential terminal of the pair that is "commoned," and these terminals are often kept at their constant potential by earthing, as shown in Fig. 2(a). The basic valve circuit "configurations," as they are termed in America, are distinguished by the electrode that is common to both input and output. With a triode there are therefore three of them, called by true Britons "earthed-cathode,"

“earthed-anode” (or, for other reasons, “cathode follower”) and “earthed-grid.” Americans, in accordance with national custom and therefore quite logically, say “grounded” instead of “earthed.” Certain persons in this country, contrary to national custom and even their own custom in other contexts and therefore quite illogically, also say “grounded.” In view of this situation, which almost led to an unedifying fight between a contributor and the Editor,[§] I have decided to fall in with a growing practice on both sides of the Atlantic and abandon both words in favour of “common.” Not only is this free from any taint of nationalism but it more truly describes the condition, earthing not being the really essential feature. The earth symbol in Fig 2(a) and other diagrams is there mainly to call attention to which is the common low-potential electrode.

The Preferred Circuit

Theoretically, one could argue that there are six basic configurations. For each of the three choices of common terminal there is a choice of which of the other two is to be input and which output. But in each case only one of these gives amplification, so the other is not usually counted.

With valves, the common-cathode arrangement is the original and by far the most commonly used, so the accepted practice has always been to measure valve characteristics in this condition and to reckon voltages relative to cathode—hence my strong preference for the convention shown in Fig. 2(b), where the artificial anode generator gives *minus* μv_{kg} volts relative to *k*, and the positive direction of signal current is from *k* to *a* as indicated by the arrow, opposite to the steady d.c. component. Otherwise one has to suppose that this generator acts from *a* to *k*, contrary to the convention of regarding *k* as the starting point.

But that is by the way. The important thing just now is the fact that there is, and always has been, no doubt at all about which of the three configurations is assumed when mentioning the two essential triode “parameters,” as they are called: r_a and μ . If the first use of triodes had been as cathode followers it would have been quite different: as we shall soon see, μ would always have been less than 1, and r_a much less than we are used to, and derivation formulae would have been necessary to derive the values applicable in Fig. 2(b).

Another important point is that, thanks to the non-conducting grid path, there are only these two basic parameters, r_a and μ . But what, you may say, about the mutual conductance g_m ? Although g_m is nearly always included among valve data it does not make a third basic quantity, because if the first two are known it is known too, being equal to μ/r_a . Moreover it is not needed at all in the well-known form of equivalent circuit we have seen—Fig. 2(b). But as an alternative to this equivalent, with its voltage generator in series with r_a , there is another form, with a current generator[¶] in parallel with r_a —Fig. 3. One can show (as I did in the April 1951 issue—“That Other Valve Equivalent”) that it

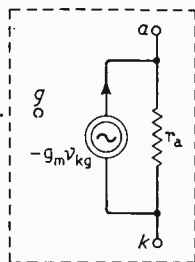

Left: Fig. 3. An alternative to the voltage generator in series with r_a is a current generator in parallel.

Below: Fig. 4. (a) the cathode follower or common-anode circuit. (b) The circuit equivalent of the valve, adapted to be in terms of the signal e.m.f. v_{ag} .

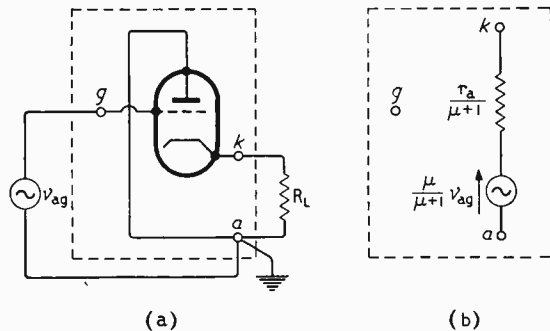

always gives exactly the same results. But it is sometimes more convenient; especially with tetrodes and pentodes, which are covered by the triode equivalent circuits so long as the extra electrodes are tied down to constant potentials. Their μ and r_a are so high that Fig. 3 is the more natural choice; in fact, if the load impedance is very low compared with r_a , r_a can be omitted without making much difference to the calculations.

Since in Fig. 3 the load impedance comes directly in parallel with r_a , it is more logical to think of it as a load *admittance*, which can be added directly to the anode *conductance* $g_a (= 1/r_a)$ to give the total admittance fed by the current generator. I just mention this to show that although (within the restrictions we have assumed) there are only two basic valve parameters, one can make for oneself quite a wide choice as to which two, some being more convenient for some purposes and others for others. Fortunately the relationships between them are simple, so that (as we have seen) it is quite easy to transfer from μ to g_m or from r_a to g_a . And there is no risk of the situation getting out of hand; there are clear reasons for quoting primarily μ and r_a for triodes and g_m and r_a or g_a for tetrodes and pentodes, and nobody is in any doubt about the common-cathode being the configuration to which they apply.

But the other two configurations are used quite frequently, so we must see what happens about their equivalent circuits. Let us take the common-anode circuit or cathode follower first. Fig. 4(a) is the circuit diagram in its simplest form. The valve could of course be drawn with its terminals in the same positions as in Fig. 2(a), but the diagram would then be difficult to recognize as a cathode follower, so I have drawn it in the customary manner with the low-potential terminal brought down to the foot. In a practical circuit, of course, there would be a blocking capacitor between this and the anode so as not to short-circuit the h.t., but to signals there is (or should be) effectively a short-circuit.

[§]“Grounded Grid” A.F. Amplifier,” by Thomas Roddam, *Wireless World*, May 1954, p. 214.

[¶]There seems to be no standard circuit symbol for a current generator; the one shown here is often used, but I am sure it could be bettered. An important requirement is that a current-generator symbol should suggest a source of infinitely high impedance, incapable of acting as a shunt to r_a .

Fig. 2(b), let us take care to note, is still a valid circuit equivalent of the valve, because within its dotted line the valve itself is no different for being in a cathode-follower circuit or any other, provided it gets its proper ration of d.c. But Fig. 2(b) is not a convenient equivalent now, because it is based on v_{kv} , which is not shown in Fig. 4(a). Moreover, although true, it is misleading, because v_{kv} is affected by any external voltage applied across ak , which causes the equivalent internal generator to behave in such a way as to make the resistance seem lower than r_a .

So the normal practice is to recalculate the resistance and generator e.m.f. in terms of the external signal voltage v_{ag} , and the result is shown in Fig. 4(b). Note that although the generator arrow is still pointing upwards the path itself has been reversed to match diagram (a), since the low-potential terminal of the output is now a instead of k . This reversal cancels out the minus sign that was needed in Fig. 2(b), and means that the output voltage has the same polarity as the input. Note that the equivalent generator e.m.f. and resistance are in terms of the common-cathode parameters r_a and μ , but that is simply a tribute to the relative importance of the common-cathode configuration. There is nothing to stop anyone measuring valves' internal resistances and amplification factors with the common-anode connection and inventing symbols for them, say r'_a and μ' . However, as these would be relatively seldom used and their equivalents in Fig. 4(b) are not difficult to remember, there would be no great point in the exercise, so they are not included in published valve data.

Just in case there are any lingering doubts about the two equivalent circuits, Figs. 2(b) and 4(b), being equivalent to one another, let us take a simple numerical example. Suppose the valve used in the cathode follower circuit, Fig. 4(a), has a μ of 24 and r_a of $10\text{ k}\Omega$, and that the load resistance R_L is

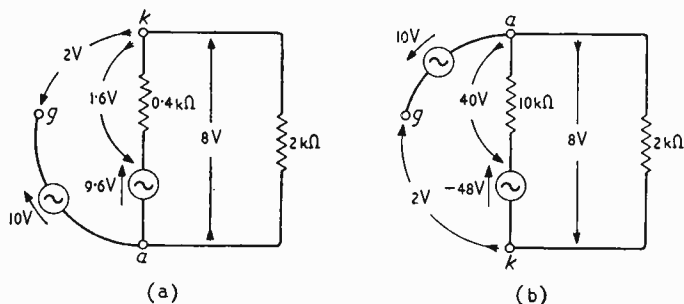

Left: Fig. 5. Numerical calculation of a particular cathode follower, using (a) the valve equivalent devised especially for cathode followers and shown in Fig. 4(b), and (b) the common-cathode equivalent shown in Fig. 2(b).

Below: Fig. 6. (a) Common-grid circuit, showing the signal source resistance R_s , because this affects the signal voltage actually reaching the valve. (b) Equivalent circuit of the valve, in terms of the source e.m.f. v_s .

$2\text{ k}\Omega$ and the input (v_{ag}) is 10V . Then, using the Fig. 4(a) equivalent circuit we calculate the internal resistance as $10/25 = 0.4\text{ k}\Omega$, and the internal generator voltage as $24/25 \times 10 = 9.6\text{V}$. This 9.6V is distributed between the internal resistance and R_L in proportion to their resistances, so R_L 's share works out at $9.6 \times 2/(2 + 0.4) = 8\text{V}$, as shown in Fig. 5(a). Note that this makes the net input to the valve—from cathode to grid— 2V , being the difference between the gross input of 10V and the 8V output fed back as a result of the signal being connected from anode.

Now make the same calculation using the other equivalent, Fig. 2(b). Here the internal generator voltage is $-\mu$ times the net input v_{kg} , which we now

know to be 2V . It is therefore -48V . But this apparent increase in voltage is exactly offset by the higher internal resistance, $10\text{ k}\Omega$. So the output is again 8V —Fig. 5(b). The minus sign for the generator voltage doesn't make any difference, because in this equivalent circuit the generator voltage is reckoned from cathode. The output voltage is still in the same direction as with the other equivalent, reckoned from anode. Although the second method of calculation gives the same answer as the first, it is less convenient, because we had to know the answer in order to find it. The first method, on the other hand, gives it direct from the gross input, v_{ag} .

More Like a Transistor

Lastly, the common-grid circuit, Fig. 6(a). Though not drawn in quite the usual way, it should be easily recognizable. Again, Fig. 2(b) is still a true equivalent, but again it is misleading. Unlike the other two circuits, with this one the load is connected between anode and grid, which means that the signal source is in series with the current-carrying path through the valve, and so the impedance of this source comes into the problem and must be shown. In Fig. 6(a) it is the resistance R_s . Because of it, the e.m.f. of the source is not the same as the voltage between k and g , so cannot appropriately be called v_{kg} . I have, therefore, marked it v_s ; and as that label does not indicate its direction an arrow is shown instead, to make quite clear that this time, because g is the low-potential terminal, the input is reversed. The high-potential terminal of the output is a , the same as in Fig. 2, so again there is one reversal to cancel out the minus, giving the output the same polarity as the input.

Although the valve equivalent generator voltage, μv_s , makes no allowance for the loss in R_s , that is all right because the loss is exactly allowed for by

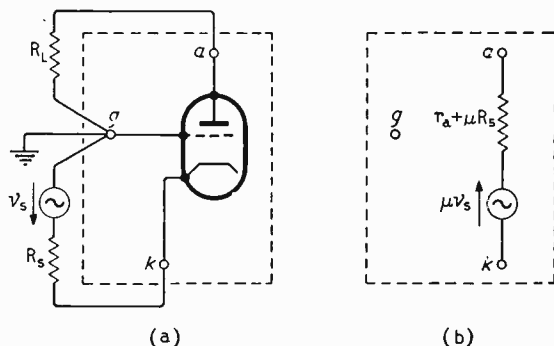

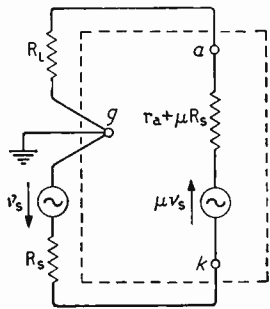

Fig. 7. Circuit diagram for calculation purposes, obtained by substituting Fig. 6(b) in Fig. 6(a).

the addition of μR_s to r_a in the internal resistance. The reason for the multiplier μ is that the voltage drop across R_s affects the voltage between cathode and grid, and this effect is amplified by the valve.

The fact that the input and output circuits are connected directly in series with one another means that the resistance "seen" by each when it is connected depends on the resistance of the other—that is to say, something outside the valve—and makes this configuration more like a transistor circuit than the other two. This point of resemblance to the transistor is interesting, and to get ourselves in training for transistor circuits let us reckon what the input and output resistances are. By "input resistance" I don't mean R_s , the resistance of the input circuit, but the resistance the input circuit works into between g and k .

Input and Output Interaction

Take the output resistance first. Substitute Fig. 6(b) for the valve in (a), to give Fig. 7, and add up the resistances from a to g through the valve and input circuit. There is $r_a + \mu R_s$ and R_s , so the total is $r_a + (\mu + 1)R_s$. Clearly that could be a lot higher than r_a , which is what one gets in the common-cathode circuit.

Now the input circuit. One might suppose that it sees $R_L + r_a + \mu R_s$. But just as in Fig. 4 a voltage applied between the output terminals gets to the grid and causes an amplified current to flow through the source of the voltage, giving it the impression that it is feeding a much lower resistance than r_a , so in Fig. 6 the source of input voltage drives a current through itself, since it is in series with the output circuit. That current is equal to the total e.m.f. acting (which Fig. 7 shows to be $(\mu + 1)v_s$) divided by the total resistance, $R_L + r_a + (\mu + 1)R_s$:

$$i = \frac{(\mu + 1)v_s}{R_L + r_a + (\mu + 1)R_s}$$

But the signal source, knowing nothing about the internal generator, imagines its own e.m.f. is causing all this current, and judges the input resistance to be v_s / i , less its own internal resistance R_s :

$$R_{in} = \frac{R_L + r_a + (\mu + 1)R_s}{\mu + 1} - R_s$$

$$= \frac{R_L + r_a}{\mu + 1}$$

That is very low—much lower than the output resistance—so this valve circuit resembles a transistor amplifier quite closely. But there is still the absence of grid current to simplify the equivalent circuit. It may help us to tackle the more difficult problem

next month if we sum up the points about valves that we should keep in mind:

(1) There are three possible two-terminal paths through a triode (including a tetrode or pentode)—grid to cathode, grid to anode, and cathode to anode—but under working conditions there is no grid current, so only the last of these three is a current-carrying path and, therefore, is the only one to appear in any equivalent circuit diagram.

(2) Consequently there are only two basic parameters—one to specify the resistance of the single current-carrying path, and the other to specify the control over it possessed by the grid.

(3) Because the valve has only three terminals, the input and output pairs of terminals must have one in common.

(4) Depending on which of the three valve electrodes is connected to the common input-output terminal, there are three "configurations" or basic arrangements of a valve in its circuitry.

(5) Of these three configurations, the common-cathode one is by far the most important, so is universally accepted as the choice for measuring the valve parameters. The standard symbols for these parameters— r_a and μ —are therefore well understood to refer to common-cathode connection.

(6) The parameters for the other two configurations are usually given in terms of the common-cathode symbols; no special symbols for them have been officially appointed.

(7) Although any equivalent that may be devised to represent the valve is valid for any circuit configuration in which the valve may be placed, for practical convenience the equivalent is devised so as to be in terms of the quantities that are known in that particular configuration.

(8) For some purposes it is convenient to use derivatives from the two basic parameters, especially μ/r_a and $1/r_a$. These are sufficiently important to have been given the special symbols g_m and g_a respectively; and often g_m is the quantity to be directly measured, rather than μ .

(9) Because there are two elements in each equivalent circuit diagram there are two varieties of it—series and parallel.

It will be by comparison with these valve facts that we will attempt to bring some order out of the transistor chaos.

STEREOPHONIC HEAD

A COMBINED playback and recording head for twin-channel stereophonic tape records has been developed by Truvox, Ltd., 15, Lyon Road, Harrow, Middlesex. It is available as a separate unit and costs £14 10s.



Truvox TR2049 stereophonic recording / playback head

The windings are of high-impedance type (50 k Ω at 10 kc/s), and are stated to have a frequency range, with suitable amplifiers, of 50 c/s to 15 kc/s. The gap width is 0.00025in.

For recording a bias voltage of 120V, r.m.s. is recommended with a recording current of approximately 0.1 mA. The output on playback is of the order of 1 to 3 mV.

Four-Standards Television

Problems of Receiver Circuit Design
in Belgium

By *H. de LAISTRE BANTING*, A.M. Brit. I.R.E.

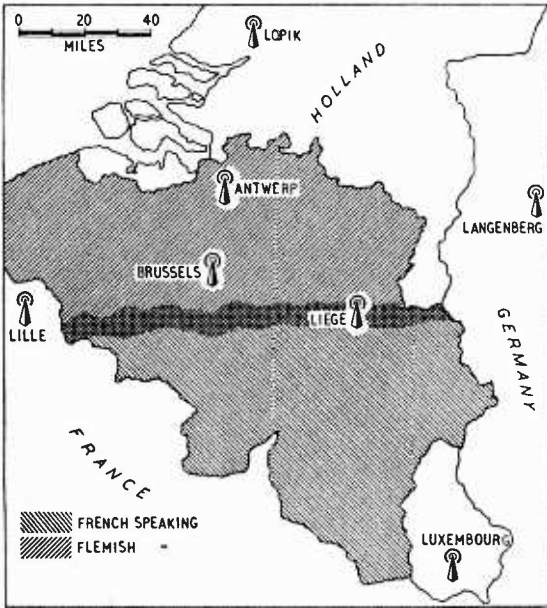

Fig. 1. Map showing relationships between the Belgian language groups and the television stations of neighbouring countries providing a useful signal for Belgian viewers.

TELEVISION engineers visiting Belgium are usually surprised to find that the four-standards problem which we have here must be solved for almost every viewer. The present receiver market, although small by comparison with that in Britain, is expanding rapidly. Even so, the call for simple television sets able to receive one or two stations of similar transmission characteristics is virtually non-existent, a fact which will be more readily understood if one takes into account the psychological factors present.

There are two major languages spoken in this small country of 8,000,000 inhabitants, French in the south and part of the east, and Flemish in the north and part of the west. In addition, in parts of the south-east, German is spoken, although a large part of the population is able to understand both French and Flemish more or less fluently. A glance at a map, Fig. 1, will therefore indicate the origin of some of the problems. The Flemish living on the French border wish to receive Dutch and German transmissions, while the French-speaking viewers on the Dutch and German borders go to extraordinary lengths to get acceptable pictures from Lille.

One may look hopefully towards the Grand Duchy of Luxembourg, which transmits in French. This is very acceptable to the sparse population of southern Belgium, but most upsetting to the viewers in the Grand Duchy, who normally speak German and tune their sets to the German station situated in the Black Forest. At all events the Luxembourg transmissions are, in fact, intended for France!

It will thus be seen that for a very long time to come the demand for all receivers in Belgium and the Grand Duchy must inevitably be for "fringe-area" models able to receive any type of transmission current in Europe except the "8-Mc/s channel

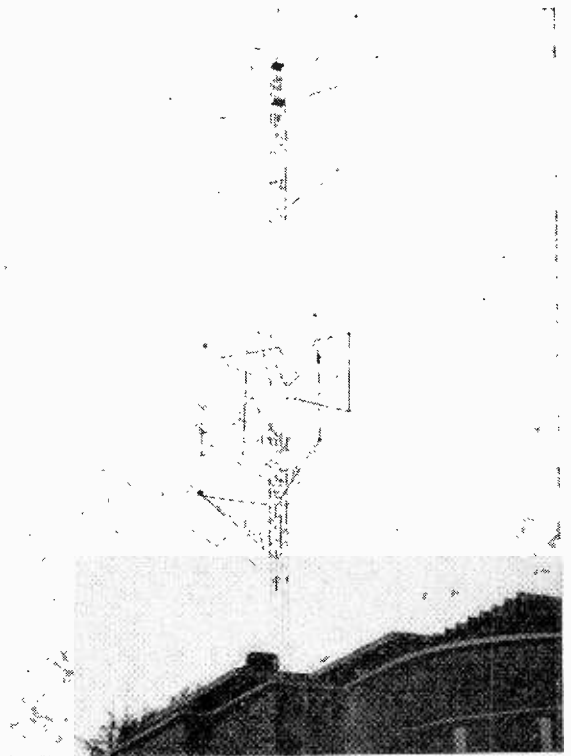

Fig. 2. Elaborate television aerial on a private house in the Avenue Terveuren, Brussels.

C.C.I.R." from the U.S.S.R., which is nevertheless receivable in some parts of Benelux. Furthermore, except for Lopik in Channel 4, Liège in Channel 3 and Antwerp in Channel 2, all stations are in Band III.

The aerial systems are necessarily in keeping with the viewer's determination not to miss anything! Fig. 2 shows one of the more exaggerated private installations in Brussels. Throughout the country, and in the Grand Duchy, one can see 7 to 10-element stacked Yagis mounted on masts well over 100ft high. In fact one of the standard masts sold

is 30 metres high and fitted with a rotary mechanism. This sort of thing is more understandable when one considers the location of many of these people living in the country districts without other forms of entertainment, to which is added the language difficulty already explained above. As elsewhere in Europe, a great deal of Belgian television is to be found in the cafés.

From Table I we see the principal differences between the various standards. It is not often realized abroad that during a Belgian programme the announcer will ask viewers to switch from 819 lines to 625 lines or vice versa. This is because Belgian stations retransmitting a Eurovision programme do not "convert" the number of lines except in the case of programmes originating from the B.B.C. This state of affairs immediately precludes coupling the line timebase frequency switch to the channel selector, which would have seemed the obvious thing to do.

The reader will no doubt have thought of the hum problem, which could be solved only by synchronizing the mains of all neighbouring countries. There is another aspect which is fraught with danger. The daily retransmissions in Belgium of the Paris programme are done by using only the picture (on half-bandwidth), and substituting the Belgian sync waveform. In the early days this was disastrous for the flywheel line timebase. Synchronizing the frame

timebase in the presence of heavy impulse interference is especially difficult when using the French transmission direct from Lille, due to the fact that the frame sync waveform consists of a single pulse of 20 μ sec duration. This has the advantage of giving a somewhat better result on interlace, but the sync is made very much "weaker" by the technique.

Necessary Compromises

After a little experience of the conditions obtaining in Belgium one is forced to certain conclusions on the need for applying a number of compromises, in order to have reasonably acceptable pictures from all directions.

Due to the uncertainty of the black-level in Belgian transmissions, plus the inherent difficulties encountered in d.c. restoration on negative modulation, it is necessary to abandon the d.c. component. Automatic gain control is universally used, but is never a fully gated system. This attitude seems to be justified on the double basis that the pictures do not suffer visibly on peak-white, and that when one has a fairly large number of fringe transmissions more or less within range the inexpert viewer is not able to cope with a contrast variation depending upon the synchronization of one or other of the timebases. This is particularly important when the viewer is not sure if the transmitter in question is receivable and has no set sequence of operations to apply.

All channel selectors are fitted with coils for the C.C.I.R. Channels 2-11; in the 12th position is the French Channel 8A for Lille. This is "rearranged" by changing the oscillator from the high to the low frequency side of the vision carrier. This keeps the vision i.f. the same for all channels, but gives a second sound i.f. which is 5.65 Mc/s lower than that for the other channels. The remaining position is normally left without coils and can be used for local f.m. broadcast reception if required. Reference to Table I will make this clear.

The introduction of "transformerless" techniques was greatly complicated here by the existence of three mains voltages, 110, 130 and 220 volts. Fortunately one can ignore the d.c. mains but not so the 130 volts, which is very common. This naturally makes all voltage-doubler arrangements unpleasantly complicated, added to which the fluctuation in the mains at various times of the day is quite extra-

Table I

Origin	No. of lines	Video bandwidth (Mc/s)	Sound/vis. separation (Mc/s)	Sound car. relative to vision car.	Modulation:	
					sound	vision
France ...	819	10.4	11.15	lower	A.M.	pos.
Belgium ... (Flemish)	625	4.5	5.5	higher	A.M.	pos.
Belgium ... (Fr. lang.)	819	4.5	5.5	higher	A.M.	pos.
Luxembourg	819	4.5	5.5	higher	A.M.	pos.
Holland ...	625	4.5	5.5	higher	F.M.	neg.
Germany ...	625	4.5	5.5	higher	F.M.	neg.

Note.—All Belgian stations change from 625 to 819 lines or vice versa depending upon Eurovision relays.

Fig. 3. Typical arrangement for automatic interference reduction. On positive modulation, negative-going interference peaks cut off PL83. Earthed-grid stage provides amplified signal of same phase for sync separator. On negative modulation, sync is taken from PL83 anode.

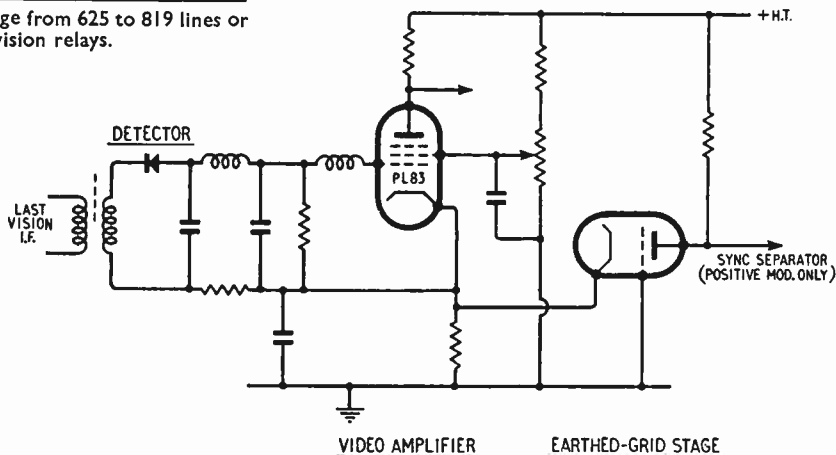

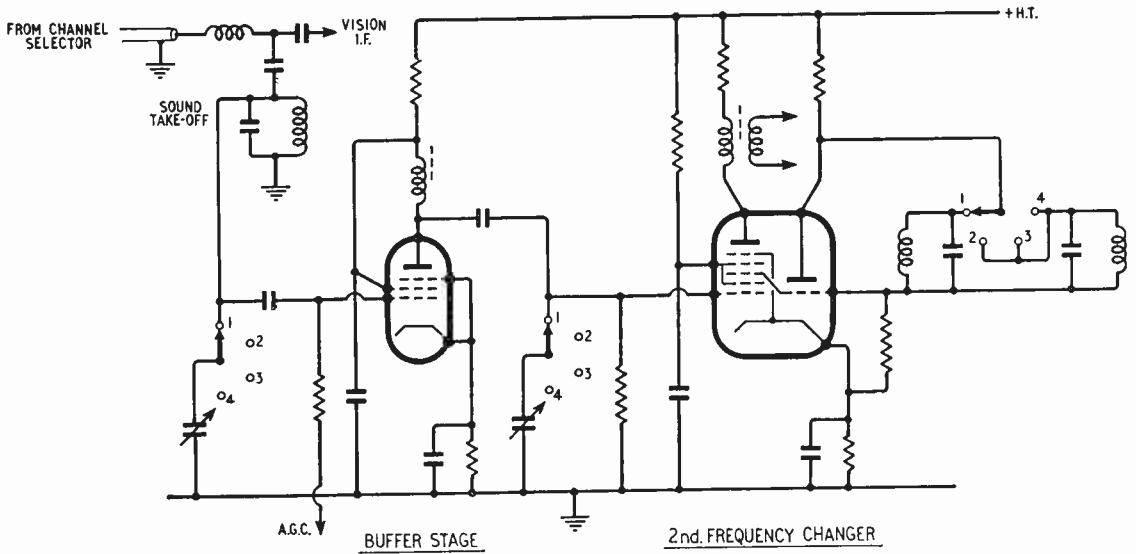

Fig. 4. Use of a second frequency changer for sound, giving a second i.f. of either 11.8 or 7 Mc/s. The buffer stage is switched between 27.75 and 33.4 Mc/s. (Switch positions: 1, France; 2, Belgium and Luxembourg; 3, Belgium and Luxembourg; 4, C.C.I.R.)

gant. One finishes by finding that the saving in cost is very much less than in Britain. In the author's opinion the only simple solution is to design for 220 volts and add an auto-transformer for the lot.

Under the conditions described the simple type of vision interference limiter used in British receivers is quite insufficient. It is usual to start with vision demodulation in the negative sense and then apply the negative-going video signal to a video amplifier which reduces the interference to a little over the maximum modulation. This is very effective but entails the use of an earthed-grid triode stage to amplify the composite video signal across the cathode resistance of the video amplifier without changing its phase, in order to provide a suitable signal for the sync separator (see Fig. 3).

Major Difficulties

Of the three purely "four-standards" problems, the sound is probably the most untidy. There are three principal systems: the use of two entirely separate sound amplifiers; the switching by capacitance of the frequency of a single amplifier; and the use of a second frequency changer. This last is the most popular because of the opportunity it presents to make use of a relatively low frequency ratio detector for the f.m. on the C.C.I.R. transmissions. The ratio detector is at present the most effective solution for the f.m. since the simpler methods of demodulation result in far too much noise on the majority of receivable transmissions.

The difficulty of this solution is to choose a frequency for the oscillator which will be the least troublesome from the point of view of r.f. or i.f. harmonics. To reduce these bad effects it is found necessary, in addition to the more obvious precautions, to use a buffer amplifier between the take-off point in the vision i.f. and the second frequency changer (see Fig. 4). This buffer must be switched in frequency for the transmissions from France because, as has already been explained, the sound

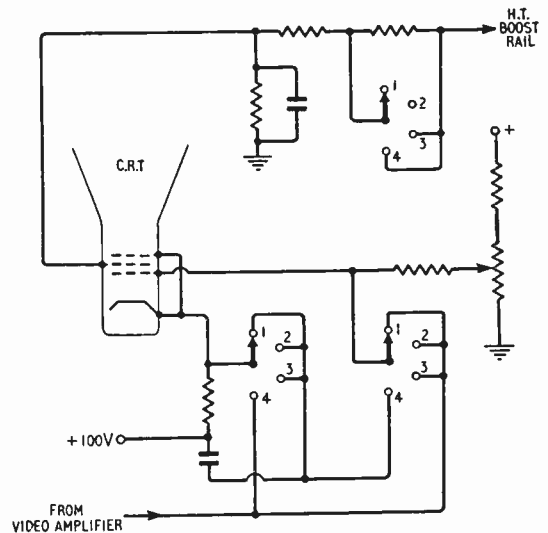

Fig. 5. Switching of c.r.t. modulation. Also, c.r.t. anode voltage compensation to maintain constant brightness when changing from 625 to 819 lines. (Switch positions: same as in Fig. 4.)

i.f. output from the tuner under these conditions is 5.65 Mc/s lower than normal. The second sound i.f. is then made either 7 Mc/s or 11.8 Mc/s. Once again the question of interference limiting is of great importance, and a simple limiter will not suffice.

Coming now to the video circuits, reference has already been made to the fact that many manufacturers prefer to use permanent negative demodulation. In this case the positive/negative switching is achieved either by switching in or out a second low-gain video stage, or more usually by switching the modulation of the c.r. tube from the grid to the cathode (see Fig. 5). In other cases the detec-

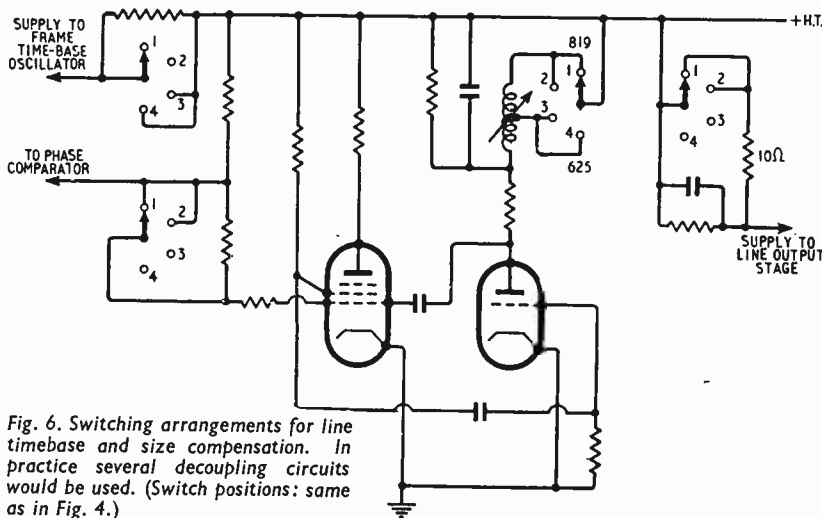

Fig. 6. Switching arrangements for line timebase and size compensation. In practice several decoupling circuits would be used. (Switch positions: same as in Fig. 4.)

process technically by either converting all Eurovision to the local standard, or, better still, abandoning the use of two different standards—if this can be done without provoking a political crisis.

A receiver with a 17in tube costs on the average £100, but more precise figures are difficult to arrive at. A customer does not normally pay the price on the ticket; he will usually insist on a rebate of 10-20% and the dealer will have to pay at least a proportion of the sales tax, which totals 13%. On the other hand, the customer seems quite happy to pay from £25 to £50 for a very

ordinary aerial array mounted on his roof.

The desirable evolution of Belgian television towards a reasonably priced, simple piece of apparatus, providing a standard of entertainment high enough to attract the customers, is a definite possibility during the course of the next year or two, if only the broadcasting authorities are not forced to take some precipitous action in colour television as a result of pressure from outside interests.

CLUB NEWS

Barnsley.—"Specialized frequency meter" is the title of the talk to be given by W Richardson (G8VX) at the meeting of the Barnsley and District Amateur Radio Club on November 9th. A fortnight later the club will hold an exhibition and demonstration of members' equipment. Meetings begin at 7.0 at the King George Hotel, Peel Street. Sec.: P. Carbutt (G2AFV), 33 Woodstock Road, Barnsley.

Belfast.—At the September meeting of the City of Belfast Y.M.C.A. Radio Club, an American spoke on amateur radio in the U.S.A. The October meeting (17th) will consist of amateur and professional tape recordings. The club meets at the Y.M.C.A., Wellington Place. Sec.: R. J. Boal (G13AXI), 127 Hillman Street, Belfast.

Birmingham.—At the meeting of the Slade Radio Society on November 9th, T. J. Hayward, of the R.A.F. School of Radio, will deal with microwave techniques. Meetings are held at 7.45 at the Church House, High Street, Erdington, Birmingham, 23. Sec.: C. N. Smart, 110 Woolmore Road, Erdington.

Bradford.—The 1956/57 syllabus of the Bradford Amateur Radio Society includes, in addition to a variety of lectures, a number of visits to works, etc., among them Mains Radio Gramophones Limited, Beckside Works, on October 23rd. Meetings are held on alternate Tuesdays at 7.30 at Cambridge House, 66 Little Horton Lane, Bradford. Sec.: F. J. Davies (G3KSS), 39 Pullan Avenue, Eccleshill, Bradford, 2.

Newbury.—W. H. Allen (G2UJ) will speak on "A Ham in peace and war" at the meeting of the Newbury and District Amateur Radio Society on November 9th at 7.30 at Elliott's Canteen, West Street.

Sidcup.—The next meeting of the Cray Valley Radio Club will be held on October 23rd and will comprise an exhibition of members' home-built gear. Meetings are held at 8.0 at the Station Hotel, Sidcup. Sec.: S. W. Coursey (G3JJC), 49, Dulverton Road, New Eltham, London, S.E.9.

tion is switched by germanium diodes, by switching the heaters of a double triode where the two "diodes" are permanently connected, or by various systems of biased diodes, which introduce decoupling difficulties. In the cases of switching the detection, it is normal to a.c. couple to the video stage, otherwise additional switching would be required to change the bias of the valve.

Although there exist receivers which employ a special amplifier to preserve the large bandwidth on French transmissions, these do not represent a significant proportion of the market. All well-known receivers use a 4.5-Mc/s vision i.f. for all signals. Of course, the channel selector must preserve the complete bandwidth in order to provide the sound signal. For this reason the gain on the Lille channel is about half that on the other channels.

Finally, there are the practical difficulties encountered in switching the line timebase speed. This naturally gives rise to a change in the e.h.t. and the h.t. boost rail, causing changes in height, width and picture brightness. These all have to be corrected, entailing a four-circuit switch. It is normal practice to adjust picture width for 819 lines and to switch a series resistance into the h.t. supply of the line output valve to give the same width on 625 lines (see Fig. 6). Vertical compensation will depend upon whether the normal h.t. or the boost rail is used for the frame timebase. The change in brightness is mostly due to variation of the anode voltage of the c.r. tube, and this is corrected by short-circuiting a section of a fixed potentiometer to give the desired correction (see Fig. 5).

Regarding the general prospects in Belgium, one may be consoled by the belief that conditions will tend to become simplified—at least so long as one does not take too seriously the recent German statements on their intentions for colour television in the near future. In Belgium, too, there is much talk of colour for the 1958 exhibition.

Naturally, as the transmissions improve technically we can hope for increased programme value. This could have the far-reaching effect of reducing interest in the four-standards receiver to the point where simple receivers would be saleable. In fact, the Belgian broadcasting authorities could assist this

Inexpensive Variable-Slope Filter

SIMPLE TREBLE ATTENUATION CIRCUIT FOR USE IN HIGH-QUALITY AMPLIFIERS

By D. M. LEAKEY, B.Sc.(Eng.), Grad. I.E.E., A.C.G.I.

IT is now generally accepted that in wide-band high-quality amplifiers it is almost essential to provide an adjustable means of limiting the high frequency response of the system in order that the best results may be obtained from the wide range of programme sources available. For the best results this high frequency cut-off should be both adjustable in frequency and in the rate of cut-off. Resistive networks as part of a feedback system can be used for this purpose. To obtain the necessary maximum rate of cut-off however it is necessary to employ twin-T resistance capacitance networks which unfortunately require close tolerance components and relatively complex switching arrangements. The filter to be described produces the same results as the feedback twin-T network but avoids the two above difficulties.

The use of an inductor might be regarded by many as undesirable but in this application the foundations for this opinion are in general almost groundless. Hum pick-up can be troublesome but, especially with relatively simple hum-bucking arrangements, in most applications can be made negligible. Harmonic distortion originating in the inductance has been found to be negligible providing the unit is used where the signal level is not too high. As a very general guide, with normal small iron-cored inductors, this level is about two volts. Similarly, ringing in the circuit is often put forward as a fault, but in general it can be shown that this is no worse than when using R-C networks producing the same frequency response.

The basic circuit for the filter is the single section, resistance terminated, constant- k filter section as shown in Fig. 1. This provides a response as shown in Fig. 2, the slope of cut-off being about 20 dB/octave. A steeper slope than this would be desirable and this can be achieved by shunting the inductor with a small capacitor so producing a simple m -derived section. The resulting response is shown in Fig. 3 from which will be seen that although a steeper cut-off is achieved the response rises again after the resonant point. In order to limit this rise so that it only approaches to within about 25 dB of the mid-frequency level it is necessary to limit the value of C_3 to about one-tenth of C_1 or C_2 . With this value an initial cut-off slope of

This article describes a simple m -derived single LC filter section which provides a variable slope of cut-off between about 40dB/octave and 6dB/octave at any selected roll-off frequency. It requires no close tolerance components and requires no initial adjustment.

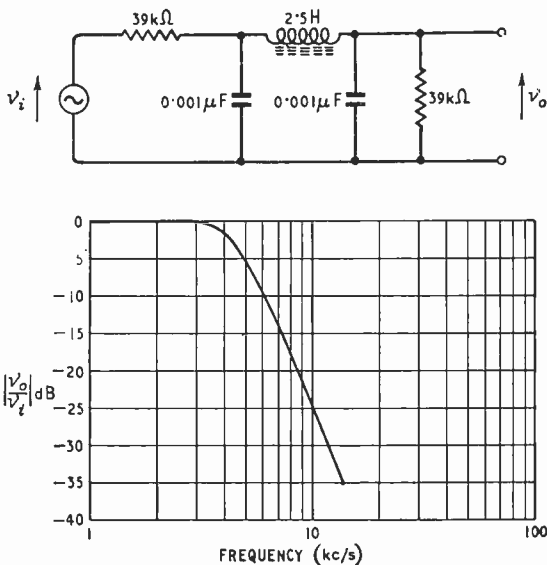

Fig. 2. Typical response of the circuit of Fig. 1.

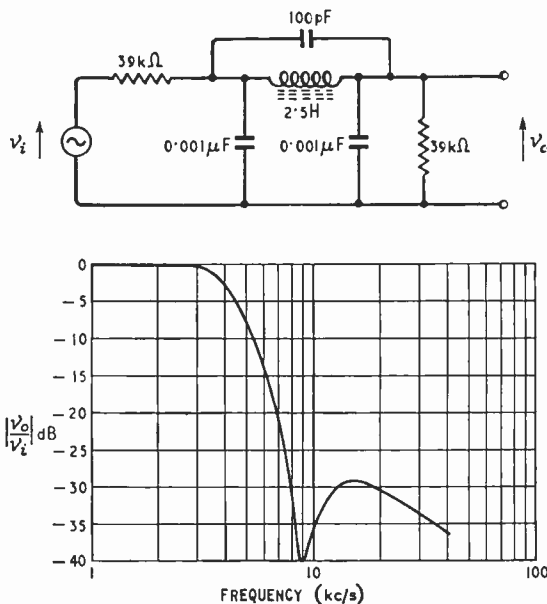

Fig. 3. A steeper slope is obtained when the series inductance is shunted by a capacitance.

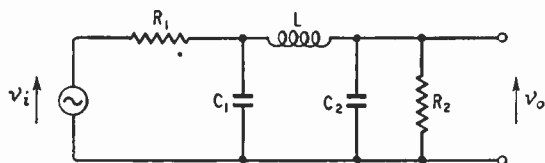

Fig. 1. Basic constant- k filter section.

40 dB/octave can be achieved whilst the response above the cut-off frequency never returns to more than within 25 dB of the mid-frequency level. A return level of 25 dB has been chosen only as an arbitrary figure which in practice has been found to be satisfactory. Actually when the m-derivation was included (i.e., the connection of C_3 across the inductor) the initial values of C_1 , C_2 and L should have been slightly modified, but due to the fact that C_3 is only one-tenth of C_1 or C_2 the error produced by leaving them at their original values is, for this application, negligible.

To achieve a variable slope of cut-off it is necessary to vary the Q of the tuned circuit formed by L and C_3 . The result of this is shown in Fig. 4 where a variable resistor R_3 is placed across L . As can be seen, the initial cut-off slope can easily be varied between 40 dB/octave and 6 dB/octave whilst leaving the cut-off frequency substantially constant.

In the above circuits a constant-voltage source is shown. This is not necessary since the input resistor R can be modified to allow for a finite source resistance. Similarly R_2 can be modified if an external load is placed across the output or C_2 modified to allow for any input capacitance of the load.

A practical circuit giving a variable slope of cut-off at about 5kc/s, 7kc/s and 10kc/s is shown in Fig. 5. It will be noticed that resistors and capacitors are switched, leaving the inductance value constant. This is purely for economic reasons bearing in mind the possible relative price of the components. For smooth slope control the variable resistor should be of the logarithmic law type. The circuit can be fed from any low-impedance source such as a low-impedance triode, or a pentode with heavy negative feedback. For the 5-kc/s cut-off condition the resonant dip can be adjusted by means of C_3 to occur at 9kc/s and so be useful as a whistle filter on medium-wave broadcast reception.

The components in the above circuit are not critical, although at least a $\pm 10\%$ tolerance on the components is preferable. The one-henry inductance can conveniently be wound on a Mullard Ferroxcube LA7 core, with about 40 s.w.g. enamelled wire. The experimental coils required about 1,100 turns for 1 henry. In practice however it is preferable to wind on say 1,200 turns, measure the inductance

and remove the correct number of turns to reduce the inductance to 1H, remembering that the inductance is very nearly proportionally to the square of the number of turns.

Humbucking can be achieved after complete assembly of the core and coil by winding turns over the complete core in reverse to the main winding. The number of turns can be found experimentally by measuring the hum pick-up of the coil when it is near a source of magnetic hum. Only a very few turns are normally required, insufficient to materially alter the inductance from the required one henry.

APPENDIX: Design of filter

IT is assumed that the known quantities are the required cut-off frequencies and the value of inductance available. L in henrys.

C in farads.

R in ohms.

f_c = cut-off frequency in c/s.

$$C_1 = C_2 = \frac{1}{2\pi^2 f_c^2 L} \quad \left. \begin{array}{l} \\ \end{array} \right\} \text{Choose the nearest } \pm 10\% \text{ value for components.}$$

$$R_1 = R_2 = \pi f_c L$$

$R_3 = 200,000 L$ (approx.) exact value is unimportant.

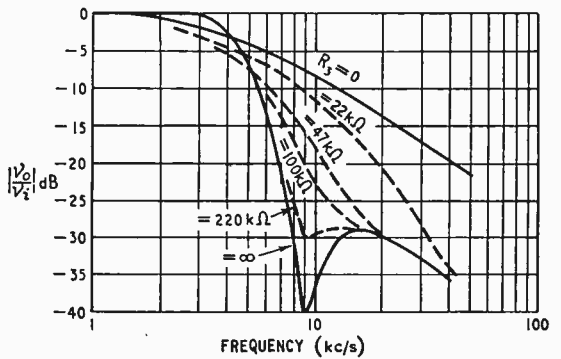
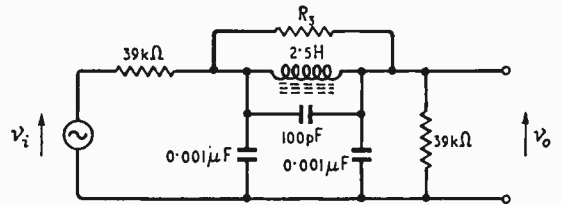

Fig. 4. Variation of slope is achieved by altering the Q of the LC circuit by means of R_3 .

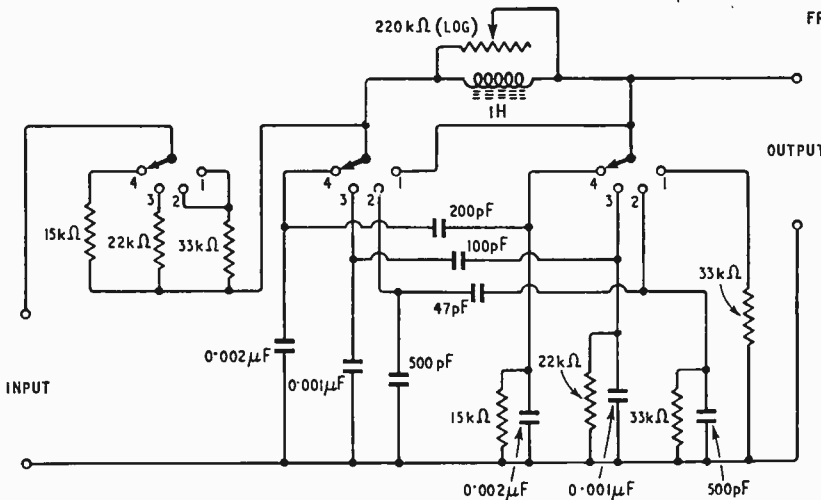

Fig. 5. Practical circuit for three switched cut-off frequencies of 5, 7 and 10 kc/s. The insertion loss at low frequencies is approximately 6dB.

NOVEMBER MEETINGS

LONDON

9th. Television Society.—“New techniques in receiver construction: printed circuits” by W. I. Flack at 7.0 at 164 Shaftesbury Avenue, W.C.2.

13th. I.E.E. (Students).—“Digital computers and how they may help the engineer” by Dr. M. V. Wilkes at 6.30 at Savoy Place, W.C.2.

14th. I.E.E.—“Frequency diversity in the reception of selectively fading binary frequency-modulated signals with special reference to long-distance radio-telegraphy” by J. W. Allnatt, E. D. J. Jones and H. B. Law. “An investigation of the spectra of binary frequency-modulated signals with various build-up waveforms” by J. W. Allnatt and E. D. J. Jones. “An improved fading machine” by H. B. Law, F. J. Lee, F. A. W. Levett and R. C. Looser. “The detectability of fading radiotelegraph signals in noise” by H. B. Law. “The signal/noise performance rating of receivers for long-distance synchronous radiotelegraph systems using frequency modulation” by H. B. Law. At 5.30 at Savoy Place, W.C.2.

14th. Radar Association.—“Infrared: its problems and possibilities” by Dr. F. E. Jones at 7.30 at the Anatomy Theatre, University College, Gower Street, W.C.1.

16th. B.S.R.A.—“Practical aspects of design and application of audio transformers” by R. B. Gilson at 7.15 at Royal Society of Arts, John Adam Street, W.C.2.

20th. I.E.E.—Discussion on “Data processing equipment for experimental work” at 5.30 at Savoy Place, W.C.2.

22nd. I.E.E.—Discussion on “The presentation and demonstration of the theory of semi-conductors to students” at 6.0 at Savoy Place, W.C.2.

22nd. Television Society.—“Alternatives to the N.T.S.C. colour system” by Dr. E. L. C. White at 7.0 at 164 Shaftesbury Avenue, W.C.2.

27th. Society of Instrument Technology.—“Television technique applied to observation and control” by Professor J. D. McGee at 7.0 at Manson House, Portland Place, W.1.

28th. Brit. I.R.E.—“Colour Television” by Dr. G. N. Patchett at 6.30 at the School of Hygiene and Tropical Medicine, Keppel Street, W.C.1.

30th. R.S.G.B.—Discussion on “1250-Mc/s operation” at 6.30 at the I.E.E., Savoy Place, W.C.2.

BIRMINGHAM

26th. I.E.E.—Informal evening on electronics and automation at 6.0 at the James Watt Memorial Institute, Great Charles Street.

CAMBRIDGE

13th. I.E.E.—Address by Dr. R. C. G. Williams, Chairman, Radio and Telecommunication Section, at 8.0 at the Cavendish Laboratory.

20th. I.E.E.—Discussion on technical education to be opened by Professor E. B. Moullin and J. Wooding at 6.30 at the Cambridgeshire Technical College, Collier Road.

CARDIFF

12th. I.E.E.—“Germanium and silicon power rectifiers” by T. H. Kinman, G. A. Carrick, R. G. Hibberd and A. J. Blundell at 6.0 at the South Wales Institute of Engineers, Park Place.

CATTERICK

22nd. I.E.E.—“Communication by tropospheric and ionospheric scatter” by Dr. J. A. Saxton and W. J. Bray at 6.15 at Catterick Camp.

CHELTENHAM

21st. Society of Instrument Technology.—“Problems in the manufacture of semi-conductors” by F. C. Carpenter at 7.0 at the North Gloucestershire Technical College.

EDINBURGH

6th. I.E.E.—“TRIDAC—a large analogue computing machine” by Lt.-Cdr. F. R. J. Spearman, J. J. Gait, A. V. Hemingway and R. W. Hynes at 7.0 at the Carlton Hotel, North Bridge.

23rd. Brit. I.R.E.—“Information Theory” by L. C. Stenning, Dr. P. Jones and P. Holroyd at 7.0 at the Department of Natural Philosophy, University of Edinburgh.

GLASGOW

7th. I.E.E.—“TRIDAC—a large analogue computing machine” at 7.0 at the Institution of Engineers and Shipbuilders, 39 Elmbank Crescent.

8th. Brit. I.R.E.—“The oscilloscope for engine testing” by R. K. Vinycomb at 7.0 at the Institution of Engineers and Shipbuilders, Elmbank Crescent.

LIVERPOOL

7th. Brit. I.R.E.—“Industrial Television” by J. E. H. Brace and R. Swinden at 7.0 at the Chamber of Commerce, 1 Old Hall Street.

LOUGHBOROUGH

20th. I.E.E.—“Ultrasonics in industry” by C. F. Brocklesby at 6.30 at Loughborough College.

MALVERN

1st. Brit. I.R.E.—“Principles of the light amplifier and allied devices” by Dr. T. B. Tomlinson at 7.0 at the Winter Gardens.

MANCHESTER

1st. Brit. I.R.E.—“Electronics applied to physiology” by H. W. Shipton at 6.30 at Reynolds Hall, College of Technology, Sackville Street.

7th. I.E.E.—Informal evening on electronics and automation at 6.45 at the Engineers' Club, Albert Square.

NEWCASTLE-UPON-TYNE

14th. Brit. I.R.E.—“Some practical aspects of echo-sounding” by A. M. Sutton at 6.0 at Neville Hall, Westgate Road.

OXFORD

14th. I.E.E.—“Automation and electronics in industry” by F. W. Highfield at 7.0 at 37 George Street.

SHEFFIELD

21st. I.E.E.—“Germanium and silicon power rectifiers” by T. H. Kinman, G. A. Carrick, R. G. Hibberd and A. J. Blundell at 6.30 at Grand Hotel.

STONE

19th. I.E.E.—“The generation and synthesis of music by electrical means” by A. Douglas at 7.0 at Duncan Hall.

WOLVERHAMPTON

14th. Brit. I.R.E.—“Electronic techniques in automation” by J. A. Sargrove at 7.15 at the Wolverhampton and Staffordshire Technical College.

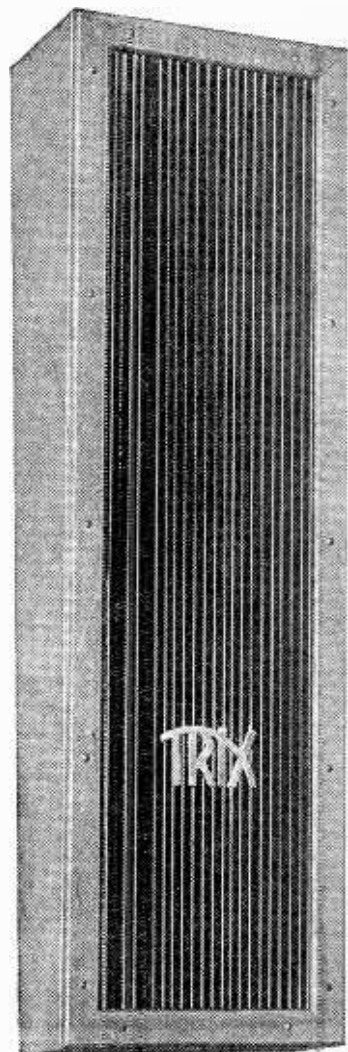

The new TRIX Sound Columns introduce a system of outstanding efficiency for sound diffusion over wide areas both indoors and outdoors. The main advantages of this type are:—

- ★ Striking improvement in acoustic efficiency.
- ★ Marked directional flat beam effect, assisting in extending coverage range with minimum reverberation and feedback.
- ★ Wiring and installation costs cut due to elimination of large numbers of single units.

TRIX

COLUMN LOUDSPEAKER

Send for full details of our complete range of equipment for every sound installation.

THE TRIX ELECTRICAL CO. LTD.
MAPLE PLACE, TOTTENHAM COURT ROAD,
LONDON, W.1.

Tel.: MUS 5817. Grams.: Trixradio, Wesdo, London

RANDOM RADIATIONS

By "DIALLIST"

819 Lines on Band I

THE first French 819-line television station operating in Band I was opened recently at Mont-Pinçon, near Caen. With its vision on 52.4 Mc/s and its sound on 41.25 Mc/s the station needs a good deal of elbow room in the ether. It occupies actually a wider band of frequencies than our Channels 1 and 2 put together; but even so the 13-Mc/s modulation range normal for 819-line transmissions has had to be somewhat reduced which must, of course, affect the picture definition. The French broadcasting authorities were afraid that it might interfere in this country with Rowridge and adopted horizontal polarization as a safeguard against this. So far, I haven't heard of any such interference, even in this present period of freak radio effects; but *Toute la Radio* states that there has been some trouble to the south of Caen in places where Mont-Pinçon and Rowridge have about the same bearing.

Slow to Catch On

THOUGH the development of the French television broadcasting network has gone forward quite rapidly, the increase in the number of TV receivers in that country has been curiously slow. There were roughly 220,000 sets in use a year ago and

the number now stands at not much over 350,000. That's a 60 per cent increase, admittedly, but even so it looks as if much water will flow beneath the bridges of France before television becomes anything like the national hobby that it is in this country, where there are now well over 6,000,000 receivers in use—the licence figure at the end of August was 6,044,330.

Nelson Effect?

IT takes some little time for W.W. to make the journey to New Zealand that's why I have only just received from a kind Wellington reader two pieces of information which throw a bright light on the "Bournemouth Effect." (June issue). That, if you remember, concerned an outburst of "chuffs" from a f.m. receiver every time a train left the station. One correspondent suggested that the effect might be due to a static charge generated by the friction of water particles driven at high velocity through air. The writer from New Zealand sends two proofs that this can happen. The first is a description published about 1870 by a lecturer at the Royal Polytechnic Institution of apparatus then used there for demonstrations and experiments. By means of a boiler, working at 60lb per square inch and provided with 46 bent iron tubes fitted

with wooden nozzles, electricity was regularly generated and sparks up to 22 inches long were obtained. His second instance seems to clinch the point, for it shows the effects of such electric charges on wireless reception. At certain times every working day there was an outbreak of horrid noises from loudspeakers in Nelson, N.Z. It was a long time before an engineer who had been trying to find the cause stumbled on the solution. He happened one day to look out of the window whilst the noises were in full blast and saw a plume of steam issuing from a factory whistle some distance away. Subsequent observations confirmed that the outburst occurred only when the whistle was in action. No one had thought of the connection since owing to the distance travelled the sound of the whistle arrived after the noises had stopped. My correspondent suggests that since Nelson, N.Z., had the effect years before Bournemouth "Nelson Effect" would be a more appropriate term—provided that the Senior Service doesn't object!

Canned Vision

A GOOD many attempts have been made to devise some workable system of recording vision on magnetic tape. Most, if not all, of these have proposed to record vision signals along a single straight-line path and one of the big snags encountered is that this would mean tape speeds of some 13,000 inches per second. In his recent application for a vision-on-tape recording system* Dr. R. D. A. Maurice, of the B.B.C. Engineering Division's Research Department, strikes out on an entirely new line. He proposes to scan a tape 1.3 inches wide by the use of what he terms "a magnetic Nipkow disc." This consists of a pair of copper discs, each containing 100 small equally-spaced slots filled with ferrite. The discs, whose distance apart is no more than about three-thousandths of an inch greater than the thickness of the tape, are locked together and driven by a motor at 6,000 r.p.m. This method would reduce the tape speed required to no more than 25 inches per second; but owing to the very

* Appended to B.B.C. Engineering Monograph No. 8.



"WIRELESS WORLD" PUBLICATIONS

	Net Price	By Post
WIRELESS SERVICING MANUAL. W. T. Cocking, M.I.E.E. 9th Edition	17/6	18/6
GUIDE TO BROADCASTING STATIONS 1956-57. Compiled by <i>Wireless World</i>	2/6	2/10
RADIO VALVE DATA: Characteristics of over 2,500 Valves, Transistors and C.R. Tubes. Compiled by <i>Wireless World</i>	4/6	5/1
SECOND THOUGHTS ON RADIO THEORY. "Cathode Ray" of <i>Wireless World</i>	25/-	26/2
THE OSCILLOSCOPE AT WORK. A. Hass and R. W. Hallows, M.A. (Cantab.), M.I.E.E.	15/-	15/10
RADIO LABORATORY HANDBOOK. M. G. Scroggie, B.Sc., M.I.E.E. 6th Edition	25/-	26/5
STUDIO ENGINEERING FOR SOUND BROADCASTING. B.B.C. Engineering Training Manual by members of the B.B.C. Engineering Division. General Editor J. W. Godfrey	25/-	25/11
RADIO INTERFERENCE SUPPRESSION: As Applied to Radio and Television Reception. G. L. Stephens, A.M.I.E.E. 2nd Edition	10/6	11/1
ADVANCED THEORY OF WAVEGUIDES. L. Lewin	30/-	30/10
ABACS OR NOMOGRAMS. A. Glet	35/-	35/10

A complete list of books is available on application
Obtainable from all leading booksellers or from

ILIFFE & SONS LTD., Dorset House, Stamford Street, London, S.E.1

small aperture used the tape would have to be capable of retaining a maximum flux density fifty times that now used.

Between Wind and Water

THE East-Coast town in which I now live has possibly had rather more than its fair share of the gales and gusty winds which have been amongst the more unpleasant features of 1956's apology for a summer. Very few aerials have been damaged by them, but a good many feeders which were not well enough anchored to prevent them from swaying to and fro have had to be replaced owing to breaks in their "inners." The most spectacular wind effect occurred here one afternoon when almost tropical rain was accompanied by gusts of the "Force 7 to 9" variety. Each gust produced ear-splitting noises from loudspeakers and firework displays on television screens. Our electricity supply is conveyed to us by overhead three-phase mains on poles. At one place the wind was swaying the sodden branch of a tree on to the cables at frequent intervals.

The Mystery that Wasn't

"THERE'S a television mystery in my house," said a friend the other day, "what happens is exactly the opposite to what you'd expect." When I asked for further enlightenment he told me that he'd had things so arranged that he could use his receiver in either of two rooms. "And here's the strange thing," he went on, "One of the rooms is much nearer to the aerial; but despite the much shorter length of feeder, you get nothing like so good a picture in it as you do in the other." I promised to drop in next time I was passing his way and when I did so I found exactly what I'd expected. The socket in the room nearer the aerial was simply Tee'd into the feeder. Hence with the set in use in that room there were yards of unused dead-end to upset the matching. The proper method is, of course, to connect the feeder to a socket in the nearer room and then to run a separate length to the other. At the far end of this length is a socket; the near end is fitted with a plug. If you want to use the set in the first room, you plug its aerial lead into the socket and the extra length of feeder is entirely unconnected. For reception in room No. 2 you plug the extension feeder into the first socket and the set's aerial lead into the second.

"THE CHOICE OF CRITICS"

SIGNAL-LAMPS

FOR ALL TYPE LAMP-CAPS

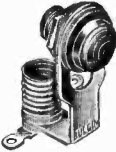

OPEN-BRACKET
M.E.S. OR M.B.C.



DESIGNED FOR
'FESTOON' LAMPS



OPEN-BRACKET
M.E.S. OR M.B.C.



NEON BULB
HOLDER (NO LENS)



GENERAL PURPOSE
M.E.S. FITTING



MAINS BAYONET-
CAP MODE.



MULTI-COLOUR
MODEL



MOULDED BODY
TYPE



CLIP-IN M.E.S.
HOLDER

★ FOR FULL DETAILS SEND FOR CATALOGUE 196/WW
Price 1/- Post Free.



BULGIN

A. F. BULGIN & CO. LTD.
BYE-PASS ROAD,
BARKING, ESSEX

Telephone: R1Ppleway 5588 (5 lines)

UNBIASED

By FREE GRID

The 1957 Exhibition

ALTHOUGH it is almost a year before the next National Radio Exhibition opens its doors it is none too soon for the organizers to begin scratching their heads in an effort to think out how an improvement can be made on this year's effort.

Now without in the least decrying the efforts of the R.I.C. this year I can think of one very great improvement which I should like to see next August. To explain what I want, I should mention that whenever I wish to buy a set, tape recorder or what have you, I invariably go to the stand of one of the big wholesalers. The reason is that on these stands I can see the products of most of the manufacturers—some possibly, who are not themselves exhibiting at the Show. There I can compare sets side by side without rushing all over the exhibition.

It is, however, not easy for an ordinary member of the public to examine the goods on these stands. They are meant only for members of the industry and the gentlemen who staff some of them are apt to freeze off outsiders in the manner of a duchess dealing with a gate-crasher. I have no difficulty as I know enough of the trade jargon to be able to pass myself off as a dealer.

I would suggest that a large section of the hall be reserved for special stands each exhibiting one class of goods only. Each stand should be staffed by people who could be relied upon not to favour one manufacturer at the expense of others.

This idea would not prevent each manufacturer having a stand of his own as at present. These special stands would be extraordinary ones in the literal sense of that word. The idea is not new, of course. For some years we had a Television Avenue at each Show, where some dozens of sets could be seen operating, but, for some unknown reason, that disappeared from this year's show.

I hope the R.I.C. will consider my idea and if it does not receive favour, I hope the learned councillors will write and tell the Editor why.

Literally Nostalgic

RECENTLY I had a personal letter from a friend living in the colonies deploring the fact that the sound of Big Ben has not been broadcast while the clock which is associated with this famous bell was out of action.

Apparently Great Tom proved an inadequate substitute. Dwellers in what used to be called the "far-flung Empire" have a sentimental interest in hearing the voice of Big Ben. It

has meant "home" to them for 30 years past and for once the B.B.C.'s overworked word "nostalgic" is literally correct.

It cannot be often that Big Ben has been out of action during the past three decades. Even if this is not the first time it is most certainly the longest period it has been silent. The B.B.C. had ample warning of the clock's long period of inaction and it seems a pity that they are so insensitive to the nostalgia associated with Big Ben in the colonies that they didn't bother to make a special recording of it. It would have been a simple technical matter for arrangements to have been made for the recording to have been triggered off at the appropriate times by signals from Greenwich.

The B.B.C. ought to be ashamed of themselves for not thinking of this idea instead of leaving me to do it for them.

Wrinkles for ROSPA*

IN the September issue I discussed an article on road safety which appeared in the American journal *Tele-Tech and Electronic Industries*. Among other things it was suggested that a capacititive system should be used so that if a car approached too close to an obstacle ahead, the brakes would be applied. I concluded, however, the range of such a system would be far too small.

The ideal solution would be for cars to be fitted with radar as the range of operation would thereby be greatly increased. Unfortunately this would mean that the car would have to tow a trailer to house the necessary apparatus. I have actually been experimenting on these lines recently and my radar trailer attracts a good deal of attention as the high superstructure necessary to house all my experimental apparatus seems to the onlookers to block my rear view entirely and they gather with ghoulish glee at strategic road junctions in anticipation of a crash.

What the crowd don't know is that, in fact, I have a perfect 180-degree rear view. I have replaced the normal driving mirror in my car by a small TV screen which is coupled to a small camera in the rear of the trailer. I see that an American car at the London Motor Show is fitted with an "electronic rear viewer." Great minds think alike.

Talking of my radar trailer reminds me that one of the worst causes of car accidents is the slow-moving pantechicon-type vehicle which completely blocks the forward

* Royal Society for the Prevention of Accidents.

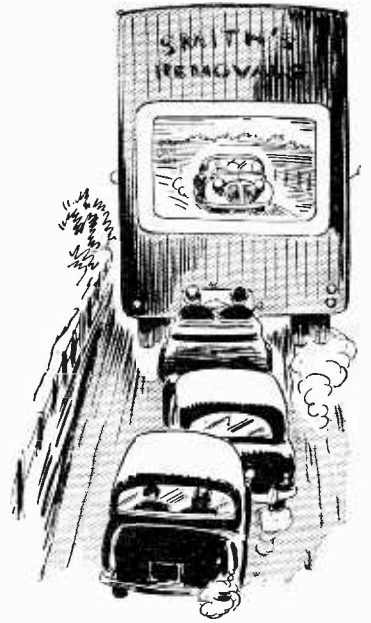

A new rôle for TV.

view of following cars. The drivers cannot see the road ahead and dare not pull out to overtake. Eventually somebody loses patience and frequently a crash occurs. In my opinion this trouble could be overcome if all these juggernauts were compelled to carry a television camera in front, coupled to a screen in the rear, so giving drivers of following cars a clear view of the road ahead.

Heard but Not Seen

WE are so used to hearing the clumsy and ugly expression "loudspeaker" to describe what would be better called the reproducer or acoustic reproducer that I was considerably surprised recently to hear it spoken of as a "soft speaker." When I queried the name I was told that there was no mistake and this correctly describes the large number of instruments which are to be installed in Guildford cathedral.

This massive new building is slowly rising on a high hill outside Guildford. It is the last word in modernity and its p.a. system has been designed to be in keeping with it. The idea of the architect is that p.a. should be heard but not seen. Special pendant chandeliers are to be designed so that each will have what is to be termed a soft speaker built into it as an integral part of its structure. Each of these instruments will give a comparatively low acoustic output but, as there will be a large number of them, the overall volume will be adequate.

Needless to say, the designer is to collaborate with the leading lights in acoustics and in loudspeaker—or "soft speaker"—design.